



PROPRIETARY NOTE

THIS SPECIFICATION IS THE PROPERTY OF BOE HF AND SHALL NOT BE REPRODUCED OR COPIED WITHOUT THE WRITTEN PERMISSION OF BOE HF AND MUST BE RETURNED TO BOE HF UPON ITS REQUEST

SPEC. NUMBER

PRODUCT GROUP

Rev.

ISSUE DATE

PAGE

TFT-LCD

1

2015.11.05

1 OF 31

AV080WVB-NW1-38P0

Product Specification Rev.1

HEFEI BOE OPTOELECTRONICS TECHNOLOGY

Contents

No.	Item	Page
1.0	General Description	4
2.0	Absolute Maximum Ratings	6
3.0	Electrical Specifications	7
4.0	Optical Specifications	8
5.0	Interface Connection	13
6.0	Power Sequence	21
7.0	Connector description	22
8.0	Mechanical Characteristics	23
9.0	Reliability Test	24
10.0	Handling & Cautions.	25
11.0	Label	26
12.0	Packing information	28
13.0	HS XRF Control Standard	29
14.0	Mechanical Outline Dimension	30

1.0 GENERAL DESCRIPTION

1.1 Introduction

AV080WVB-NW1-38P0 is a color active matrix TFT LCD FOG using amorphous silicon TFT's (Thin Film Transistors) as an active switching devices. This module has a 8.0 inch diagonally measured active area with WVGA resolutions (800 horizontal by 480 vertical pixel array). Each pixel is divided into RED, GREEN, BLUE dots which are arranged in vertical Stripe and this module can display 16.7M colors. The TFT-LCD panel used for this FOG is a low reflection and higher color type. All input signals are TTL interface compatible.

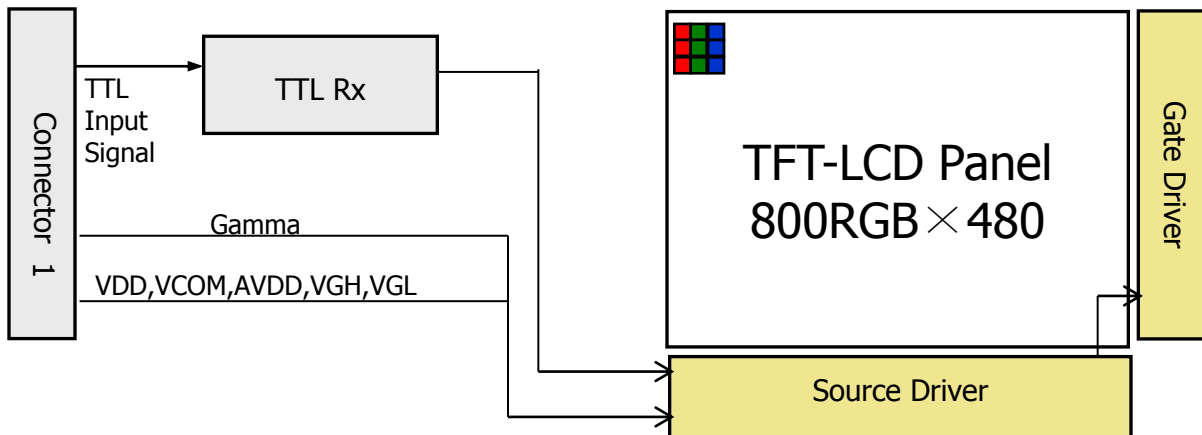

1.2 Features

- 1 Channel TTL Interface with 1 pixel / clock
- 8-bit color depth, display 16.7M colors(6-bit + FRC)
- Data enable signal mode
- Green Product (RoHS & Halogen free product)
- Low driving voltage and low power consumption

1.3 Application

- For Vehicle

1.4 General Specification

The followings are general specifications at the model AV080WVB-NW1-38P0. (listed in Table 1.)

<Table 1. General Specifications>

Parameter	Specification	Unit	Remarks
Active area	176.4(H) × 99.36(V)	mm	
Number of pixels	800(H) × 480(V)	pixels	
Pixel pitch	0.2205(H) × 0.207(V)	mm	
Pixel arrangement	RGB Vertical stripe		
Display colors	16.7M	colors	
Display mode	Normally Black		
Surface treatment	AG 25		

2.0 ABSOLUTE MAXIMUM RATINGS

The followings are maximum values which, if exceed, may cause faulty operation or damage to the unit. The operational and non-operational maximum voltage and current values are listed in Table 2.

< Table 2. Absolute Maximum Ratings >

Parameter	Symbol	Min.	Max.	Unit	Remarks
LC operating Voltage ^[1]	V _{OP}		4.3	V	Ta=25+/-2°C
Operating Temperature (Humidity)	T _{OP}	-20	+70	°C	
	RH		90	%	At 60°C
Storage Temperature (Humidity)	T _{ST}	-30	+80	°C	
	RH		90	%	At 60°C

[1] Liquid Crystal driving voltage

Due to the characteristics of LC Material, this voltage varies with environmental temperature.

3.0 ELECTRICAL SPECIFICATIONS

< Table 3. Electrical specifications >

Ta=25+/-2°C

Parameter	Symbol	Values			Unit	Notes
		Min	Typ	Max		
Power Supply Input Voltage	VDD	3	3.3	3.6	Vdc	
Power Supply Ripple Voltage	VRP			300	mV	
Analog Voltage	AVDD	10.55	10.75	10.95	V	
TFT Gate ON Voltage	VGH	19	21	23	V	
TFT Gate OFF Voltage	VGL	-9	-8	-7	V	
TFT Common Electrode Voltage	VCOM	3.85	4.05	4.25	V	
Power Consumption	PDD		330	410	Watt	1
Rush current	IRUSH	-	-	1	A	
Input Signal Voltage	ViH	0.7VDD	-	VDD	mV	
	ViL	0	-	0.3VDD	mV	
Input Level of V1~V5	Vx	AVDD/2	-	AVDD-0.1	V	
Input Level of V6~V10	Vx	0.1	-	AVDD/2	V	

Notes : 1. The supply voltage is measured and specified at the interface connector of LCM.
The current draw and power consumption specified is for VDD=3.3V, Frame rate 60Hz and Clock frequency = 30MHz. Test Pattern of power supply current

a) Typ : Check Flag

b) Max : White

4.0 OPTICAL SPECIFICATION

4.1 Overview

The test of Optical specifications shall be measured in a dark room (ambient luminance ≤ 1 lux and temperature = $25 \pm 2^\circ\text{C}$) with the equipment of Luminance meter system (Goniometer system and TOPCON BM-5) and test unit shall be located at an approximate distance 50cm from the LCD surface at a viewing angle of θ and Φ equal to 0° . We refer to $\theta_{\phi=0}$ ($=\theta_3$) as the 3 o'clock direction (the "right"), $\theta_{\phi=90}$ ($=\theta_{12}$) as the 12 o'clock direction ("upward"), $\theta_{\phi=180}$ ($=\theta_9$) as the 9 o'clock direction ("left") and $\theta_{\phi=270}$ ($=\theta_6$) as the 6 o'clock direction ("bottom"). While scanning θ and/or ϕ , the center of the measuring spot on the Display surface shall stay fixed. The measurement shall be executed after 30 minutes warm-up period. VDD shall be 12.0V +/- 10% at 25°C . Optimum viewing angle direction is 6 'clock.

4.2 Optical Specifications

<Table 4. Optical Specifications>

Parameter		Symbol	Condition	Min	Typ	Max	Unit	Remark
Viewing Angle	Horizontal	θ_3	CR > 10	-	80	-	Deg.	Note 1
		θ_9		-	80	-	Deg.	
	Vertical	θ_{12}		-	80	-	Deg.	
		θ_6		-	80	-	Deg.	
Color Gamut				45	50	-	%	NTSC
Contrast ratio		CR		600	800	-		Note 2
Luminance of White	5 Points	Y_w		-	500	-	cd/m ²	Note 3
White luminance uniformity	5 Points	$\Delta Y5$		75	80	-	%	Note 4
Reproduction of color	White	W_x	$\theta = 0^\circ$ (Center) Normal Viewing Angle	TYP. - 0.03	0.304	TYP. + 0.03		Note 5 Base on C-Light
		W_y			0.341			
	Red	R_x			0.613			
		R_y			0.330			
	Green	G_x			0.300			
		G_y			0.566			
	Blue	B_x			0.142			
		B_y			0.173			
Response Time		T_g		-	30	40	ms	Note 6
Gamma Scale				2.0	2.2	2.4		
Trans.				-	6.1%	-		

Note :

1. Viewing angle is the angle at which the contrast ratio is greater than 10. The viewing are determined for the horizontal or 3, 9 o'clock direction and the vertical or 6, 12 o'clock direction with respect to the optical axis which is normal to the LCD surface.
2. Contrast measurements shall be made at viewing angle of $\theta=0^\circ$ and at the center of the LCD surface. Luminance shall be measured with all pixels in the view field set first to white, then to the dark (black) state. (See FIGURE 1 shown in Appendix)
Luminance Contrast Ratio (CR) is defined mathematically.

$$CR = \frac{\text{Luminance when displaying a white raster}}{\text{Luminance when displaying a black raster}}$$

3. Center Luminance of white is defined as the LCD surface. Luminance shall be measured with all pixels in the view field set first to white. This measurement shall be taken at the locations shown in FIGURE 2 for a total of the measurements per display.
4. The White luminance uniformity on LCD surface is then expressed as :
 $\Delta Y_5 = (\text{Minimum Luminance of 5 points} / \text{Maximum Luminance of 5 points}) * 100$
 $\Delta Y_{13} = (\text{Minimum Luminance of 13 points} / \text{Maximum Luminance of 13 points}) * 100$
 (See FIGURE 2 and FIGURE 3 shown in Appendix).
5. The color chromaticity coordinates specified in Table 4. shall be calculated from the spectral data measured with all pixels first in red, green, blue and white.
Measurements shall be made at the center of the panel.
6. The electro-optical response time measurements shall be made as FIGURE 4 shown in Appendix by switching the "data" input signal ON and OFF. The times needed for the luminance to change from 10% to 90% is Td, and 90% to 10% is Tr.

4.3 Optical measurements

Figure 1. Measurement Set Up

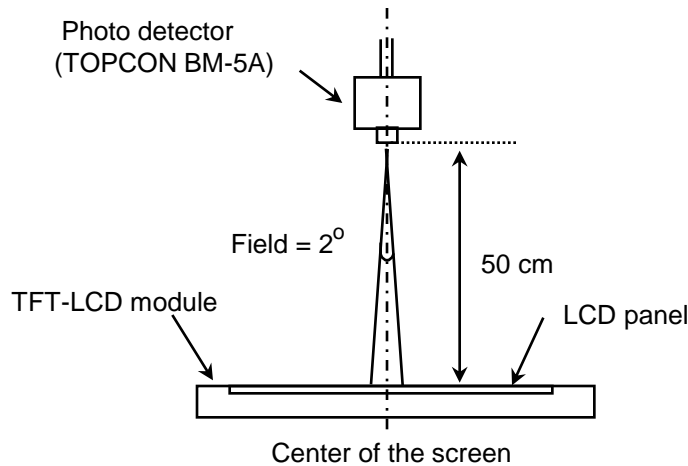

Optical characteristics measurement setup

Figure 2. White Luminance and Uniformity Measurement Locations (5 points)

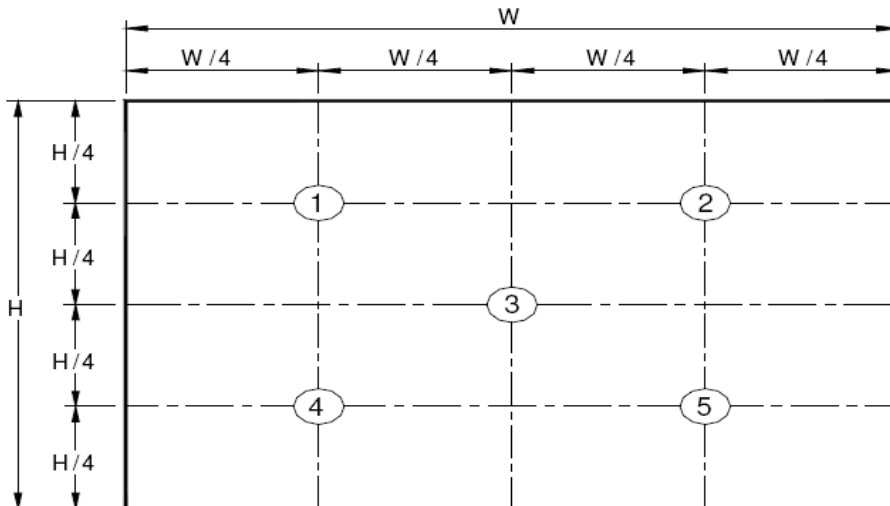

Center Luminance of white is defined as luminance values of center 5 points across the LCD surface. Luminance shall be measured with all pixels in the view field set first to white. This measurement shall be taken at the locations shown in FIGURE 2 for a total of the measurements per display.

Figure 3. Response Time Testing

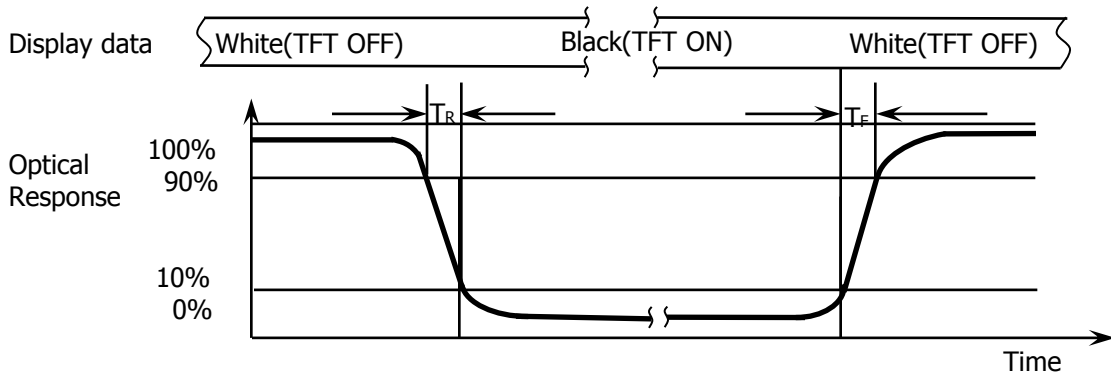

The electro-optical response time measurements shall be made as shown in FIGURE 3 by switching the “data” input signal ON and OFF. The times needed for the luminance to change from 10% to 90% is T_d and 90% to 10% is T_r .

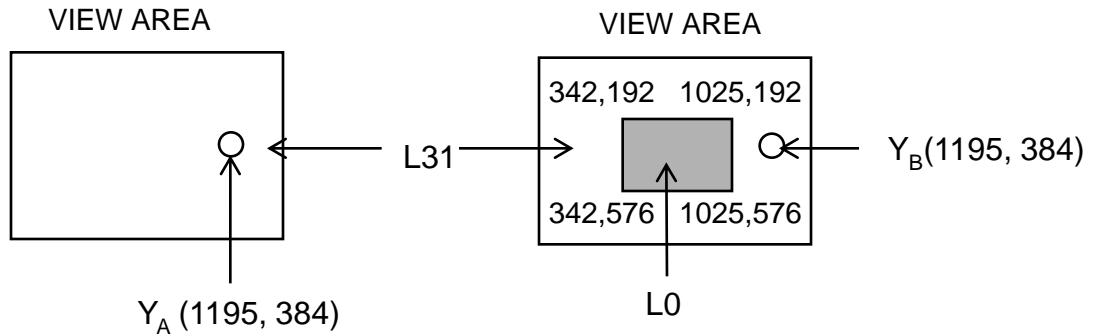
Figure 4. Cross Modulation Test Description

$$\text{Cross-Talk (\%)} = \left| \frac{Y_B - Y_A}{Y_A} \right| \times 100$$

Where:

Y_A = Initial luminance of measured area (cd/m^2)

Y_B = Subsequent luminance of measured area (cd/m^2)

The location measured will be exactly the same in both patterns

Cross-Talk of one area of the LCD surface by another shall be measured by comparing the luminance (Y_A) of a 25mm diameter area, with all display pixels set to a gray level, to the luminance (Y_B) of that same area when any adjacent area is driven dark (Refer to FIGURE 4).

5.0 INTERFACE CONNECTION.

5.1 Electrical Interface Connection

The electronics interface connector CN1 is FH12A-50S-0.5H. The connector interface pin assignments are listed in Table 5.

<Table 5. Pin Assignments for the Interface Connector>

Pin No.	Symbol	Description	Remark
1	VLED+	Power for LED backlight (Anode)	
2	VLED+	Power for LED backlight (Anode)	
3	VLED-	Power for LED backlight (Cathode)	
4	VLED-	Power for LED backlight (Cathode)	
5	GND	Power ground	
6	VCOM	Common voltage	
7	DVDD	Power for Digital Circuit	
8	MODE	DE/SYNC mode select	Note1
9	DE	Data Input Enable	
10	VS	Vertical Sync Input	
11	HS	Horizontal Sync Input	
12	B7	Blue data(MSB)	
13	B6	Blue data	
14	B5	Blue data	
15	B4	Blue data	
16	B3	Blue data	
17	B2	Blue data	
18	B1	Blue data	
19	B0	Blue data(LSB)	
20	G7	Green data(MSB)	
21	G6	Green data	
22	G5	Green data	
23	G4	Green data	
24	G3	Green data	
25	G2	Green data	
26	G1	Green data	
27	G0	Green data(LSB)	
28	R7	Red data(MSB)	
29	R6	Red data	
30	R5	Red data	

Pin No.	Symbol	Description	Remark
31	R4	Red data	
32	R3	Red data	
33	R2	Red data	
34	R1	Red data	
35	R0	Red data(LSB)	
36	GND	Power Ground	
37	DCLK	sample clock	
38	GND	Power Ground	
39	L/R	L/R selection	
40	U/D	Up/down selection	
41	VGH	Gate On voltage	
42	VGL	Gate off voltage	
43	AVDD	Power for analog circuit	
44	RESET	Global reset pin	
45	NC	No connection	
46	Vcom	Common voltage	
47	DITHB	Dithering function	
48	GND	Power GND	
49	NC	No connection	
50	NC	No connection	

Note.1

Suggest to connection with an RC reset circuit for stability , Normally pull high . (R=10K , C=0.1uF)

Note. 2

-STBYB="H (3.3V)": normal operation ;

-STBYB="L (GND)": timing controller, source driver will turn off, all output are High-Z

Note.3

Scan Control Input		Scanning direction
L/R	U/D	
VDD	GND	Up to Down, Left to Right
GND	GND	Up to Down, Right to Left
VDD	VDD	Down to Up, Left to Right
GND	VDD	Down to Up, Right to Left

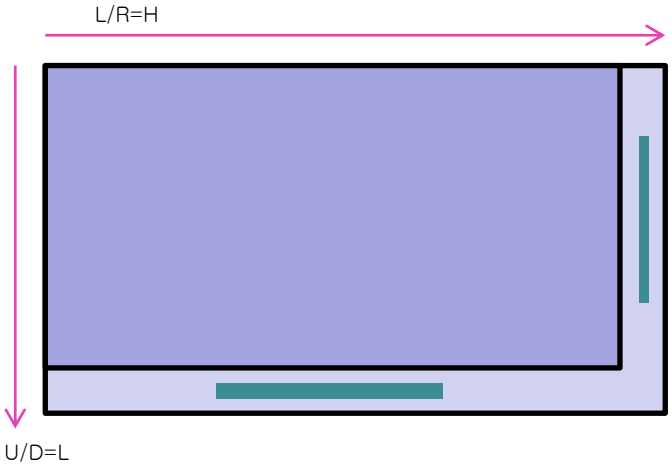

Note. 4

-DITH="1" , Enable internal dithering function

-DITH="0" , Disable internal dithering function

Note. 5

-SELB="H (3.3V)": 6 bit ;

-SELB="L (GND)": 8 bit ;

5.2 TTL Signal

< Table 6. AC Electrical Characteristics >

Parameter	Symbol	Min.	Typ.	Max.	Unit	Remark
CLKIN cycle time	Tcph	20	-	-	ns	
DCLK frequency	fclk		30		MHz	
CLKIN pulse time	Tcwh	40	50	60	%	
HS setup time	Thst	8	-	-	ns	
HS hold time	Thhd	8	-	-	ns	
VS setup time	Tvst	8	-	-	ns	
VS hold time	Tvhd	8	-	-	ns	
Data setup time	Tdst	8	-	-	ns	
Data hold time	Tdht	8	-	-	ns	
DE setup time	Tdst	8	-	-	ns	
DE hold time	Tdht	8	-	-	ns	
VDD Power On Slew rate	Tpor	-	-	20	ns	
RSTB pulse width	Trst	10	-	-	ns	
Output stable time	Tsst	-	-	6	us	

< Table 7. Timing Characteristics >

Parameter	Symbol	Min.	Typ.	Max.	Unit	Remark
Horizontal display area	thd		800		Tcph	
HSD period time	th		928		Tcph	
HSD pulse width	thpw	1	48		Tcph	
HSD back porch	thb		40		Tcph	
HSD front porch	thfp		40		Tcph	
Vertical display area	tvd		480		th	
VSD period time	tv		525		th	
VSD pulse width	tvpw		3		th	
VSD back porch	tvb		29		th	
VSD front porch	tvfp		13		th	

5.3 Timing Diagram of Interface signal

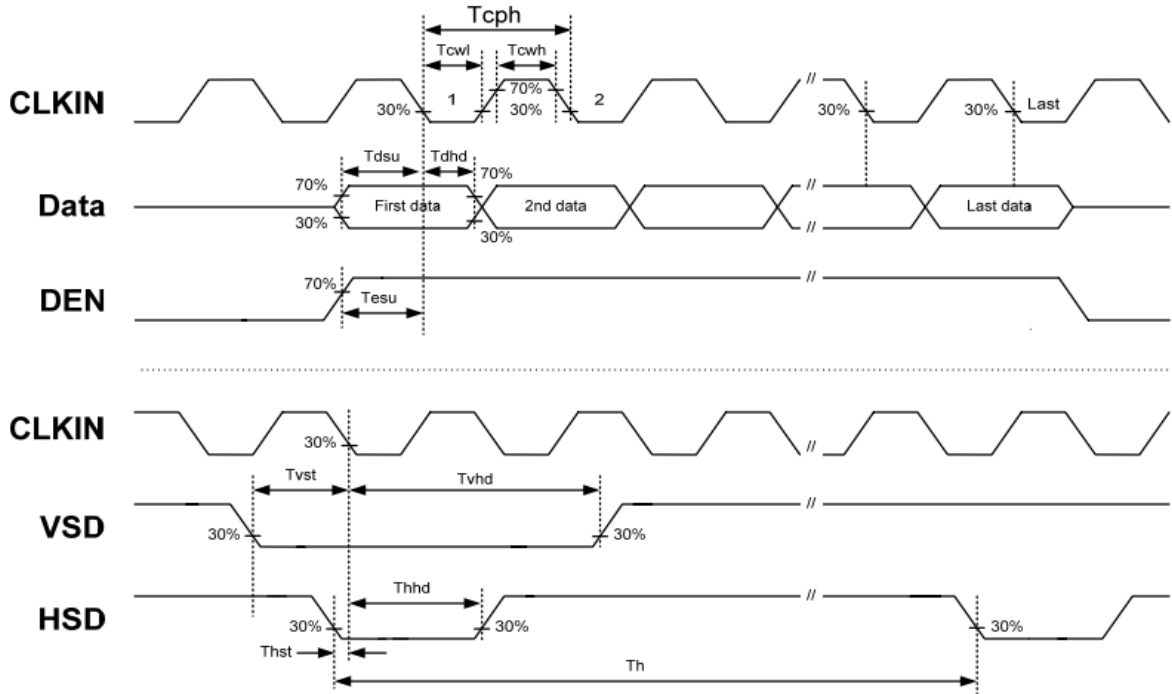

< Sampling clock timing >

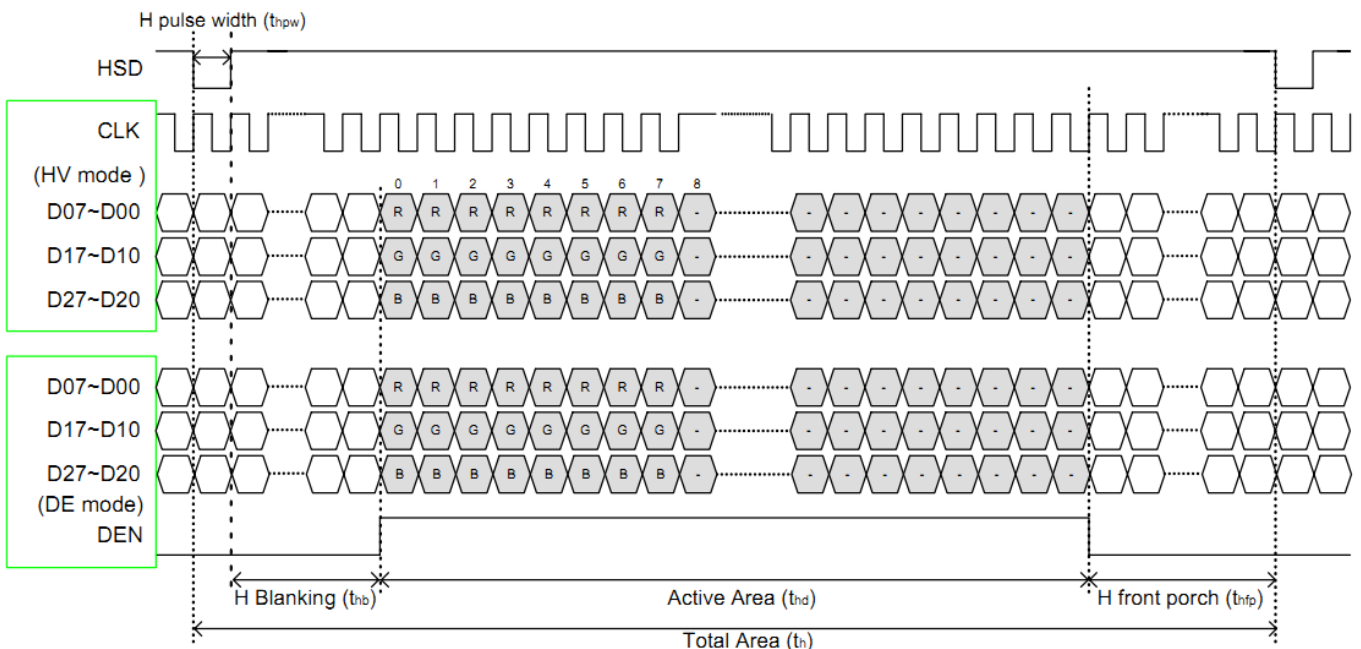

< Horizontal display timing range >

SPEC. NUMBER

SPEC. TITLE

AV080WVB-NW1-38P0 Preliminary Product Specification

PAGE

19 OF 31

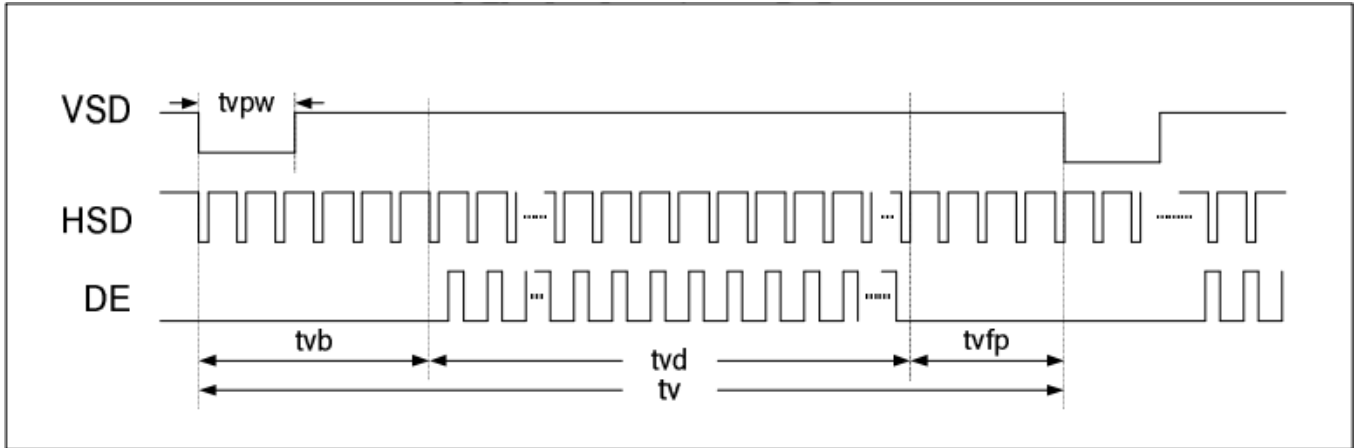

< Vertical timing >

5.4 Data Input Format

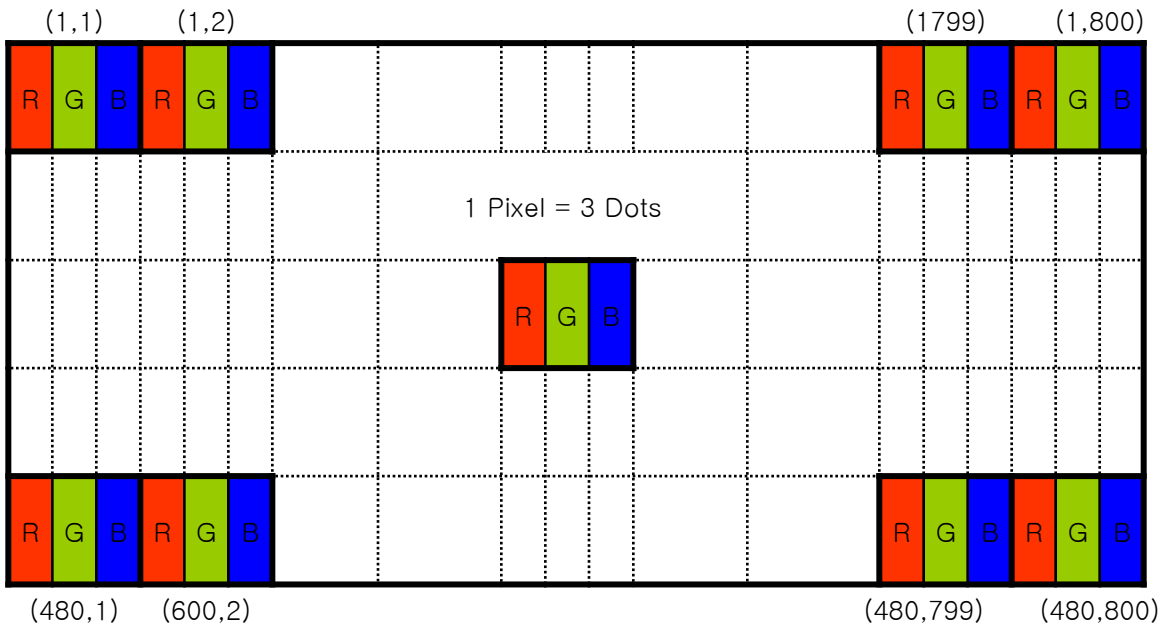

6.0 POWER SEQUENCE

To prevent a latch-up or DC operation of the LCD module, the power on/off sequence shall be as shown in below

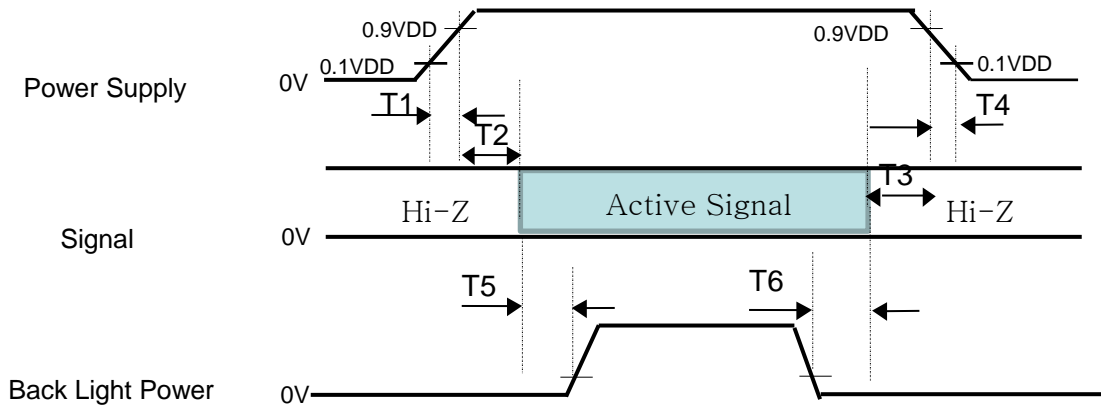

- $0.5\text{ms} \leq T1 \leq 10\text{ms}$
- $0\text{ms} \leq T2$
- $0\text{ms} \leq T3$
- $0\text{ms} \leq T4 \leq 10\text{ms}$
- $100\text{ms} \leq T5 \leq 300\text{ms}$
- $100\text{ms} \leq T6 \leq 300\text{ms}$

Notes:

1. When the power supply VDD is 0V, keep the level of input signals on the low or keep high impedance.
2. Do not keep the interface signal high impedance when power is on. Back Light must be turn on after power for logic and interface signal are valid.

7.0 Connector Description

Physical interface is described as for the connector on LCM.

These connectors are capable of accommodating the following signals and will be following components.

TFT LCD FOG

Connector Name /Description	For Signal Connector
Manufacturer	Hirose
Type/ Part Number	FH12A-50S-0.5H
Mating housing/ Part Number	-

8.0 MECHANICAL CHARACTERISTICS

8.1 Dimensional Requirements

FIGURE 6 shows mechanical outlines for the FOG AV080WVB-NW1-38P0. Other parameters are shown in Table 8.

<Table 8. Dimensional Parameters>

Parameter	Specification	Unit
Active Area	176.4(H) × 99.36(V)	mm
Number of pixels	800(H)*480(V) (1 pixel = R + G + B dots)	-
Pixel pitch	0.2205(H) × 0.207(V)	mm
Pixel arrangement	RGB Vertical stripe	-
Display colors	16.7M	-
Display mode	Normally Black	

8.2 Mounting

See FIGURE 6.

8.3 Glare and Polarizer Hardness.

The surface of the LCD has a Anti-glare coating and hard coating to reduce scratching.

9.0 RELIABILITY TEST

The Reliability test items and its conditions are shown in below.

<Table 9. Reliability Test>

No	Test Items	Conditions
1	High temperature storage test	Ta = 80 °C, 240 hrs
2	Low temperature storage test	Ta = -30 °C, 240 hrs
3	High temperature & high humidity operation test	Ta = 60 °C, 90%RH, 240hrs
4	High temperature operation test	Ta = 70 °C, 240hrs
5	Low temperature operation test	Ta = -20 °C, 240hrs
6	Thermal shock	Ta = -30 °C ↔ 80 °C (0.5 hr), 100 cycle
7	Vibration test (non-operating)	1.5G, 10~500Hz sine +X,+Y+Z Sweep rate : 60min.
8	Shock test (non-operating)	220G, Half Sine Wave 2msec ± X, ± Y, ± Z Once for each direction
9	Electro-static discharge test	Air : 150 pF, 330Ω, ±15KV Contact : 150 pF, 330Ω, ±8KV

10.0 HANDLING & CAUTIONS

(1) Cautions when taking out the module

- Pick the pouch only, when taking out module from a shipping package.

(2) Cautions for handling the FOG

- As the electrostatic discharges may break the LCD FOG, handle the LCD FOG with care. Peel a protection sheet off from the LCD panel surface as slowly as possible.
- As the LCD FOG are made from fragile glass material, impulse and pressure to the LCD FOG should be avoided.
- As the surface of the polarizer is very soft and easily scratched, use a soft dry cloth without chemicals for cleaning.
- Do not pull the interface connector in or out while the LCD FOG is operating.
- Put the module display side down on a flat horizontal plane.
- Handle connectors and cables with care.

(3) Cautions for the operation

- When the module is operating, do not lose CLK, ENAB signals. If any one of these signals is lost, the LCD panel would be damaged.
- Obey the supply voltage sequence. If wrong sequence is applied, the module would be damaged.

(4) Cautions for the atmosphere

Dew drop atmosphere should be avoided.

Do not store and/or operate the LCD FOG in a high temperature and/or humidity atmosphere. Storage in an electro-conductive polymer packing pouch and under relatively low temperature atmosphere is recommended.

(5) Cautions for the module characteristics

Do not apply fixed pattern data signal to the LCD FOG at product aging.

Applying fixed pattern for a long time may cause image sticking.

(6) Other cautions

Do not disassemble and/or re-assemble LCD FOG.

Do not re-adjust variable resistor or switch etc.

When returning the module for repair or etc., Please pack the module not to be broken. We recommend to use the original shipping packages.

11.0 LABEL

11.1 Product label

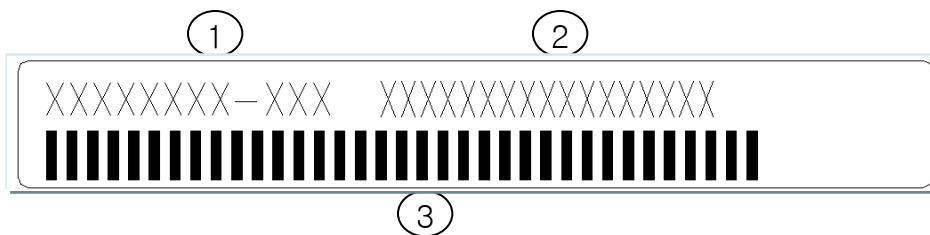

Label Size: 35mm × 6mm

1. **FG-CODE**
2. **MDL ID 条形码**
3. **MDL 信息, 编码规则如下**

序号号	1	2	3	4	5	6	7	8	9	10	11	12	13	14	15	16	17
代码	4	F	P	3	1	5	3	3	8	P	0	0	0	1	E	E	J
描述	GBN代码		等级	B3	年份		月	FG Code后四位				序列号					

11.2 Box label

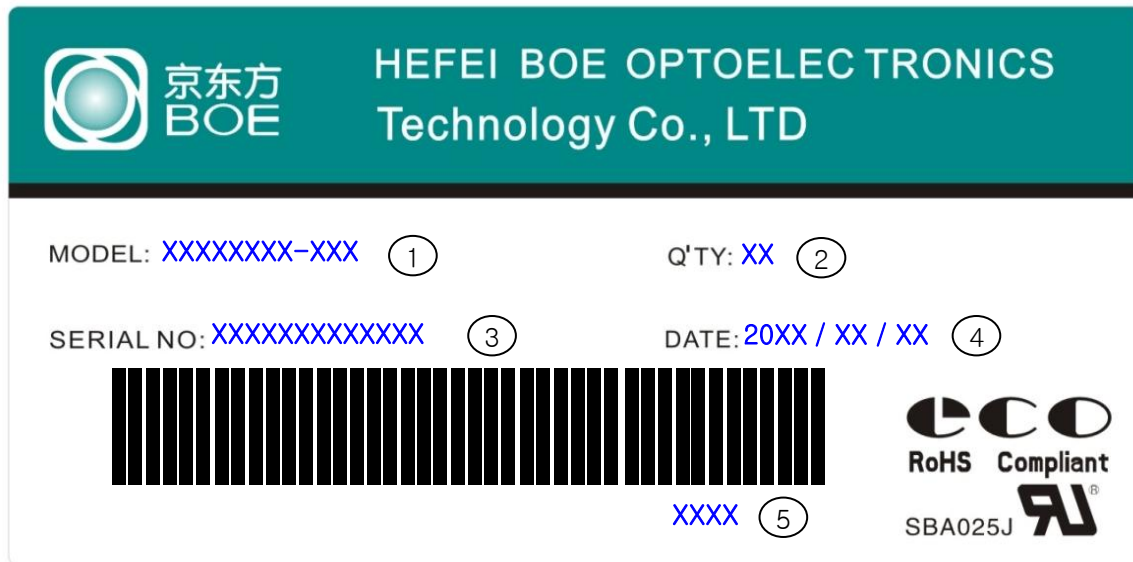

110 mm (L) × 56 mm (W), 蓝色字体为后打印标识,

1. FG-CODE
2. Box 产品数量
3. Box ID, 编码规则如下
4. Box Packing 日期
5. FG-CODE 后四位

序列号	1	2	3	4	5	6	7	8	9	10	11	12	13
代码	X	X	X	3	X	X	X	X	X	X	X	X	X
描述	GBN代码		等级	B3	年份		月	Rev	序列号				

12.0 PACKING INFORMATION

Packing Order

- 将Panel 水平放入PET Tray

- 将26pcs PET Tray 平放入屏蔽袋进行抽真空;

- Tray 不区分旋转180°放置, 顶部1pcs 空Tray;

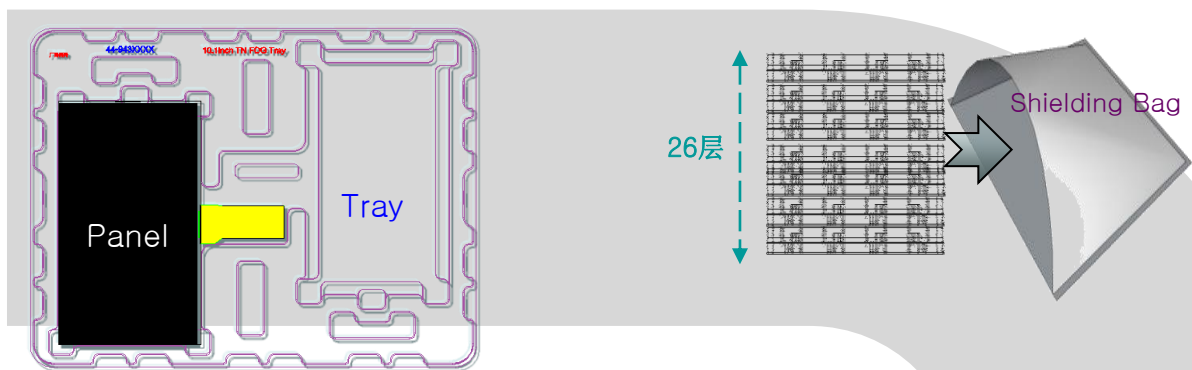

- 每个Pallet上放3层Box

1层4箱, 共计12ea Box

- Pallet 打包带&缠膜包装

- 容量: 600pcs/Pallet

- 将Tray 放入纸箱, 上下放置EPE Cover,

50pcs/ Box

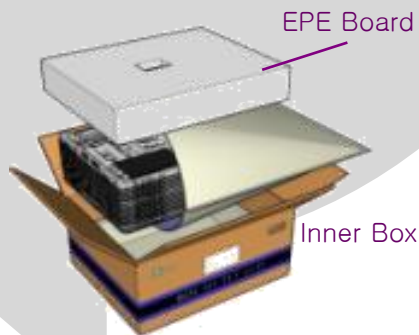
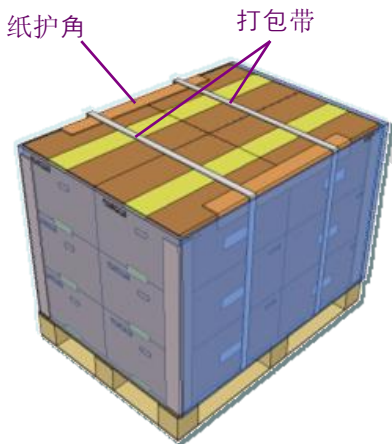

● Box Dimension: 500mm(W) x 400mm(D) x 300mm(H)

● Package Quantity in one Box: 50pcs FOG/Box

13.0 HS XRF Control Standard

HS XRF 管控标准

限制物质和最大容许含量	RoHS 标准	BOE HF标准	XRF管控标准
镉 (Cd)	100PPM	5PPM	$P = ND < X < 15ppm \leq F$
铅 (Pb)	1000PPM	100PPM	$P \leq 70ppm < X < 130ppm \leq F$
汞 (Hg)	1000PPM	ND	$P = ND < X < 10ppm \leq F$
		(CCFL: < 3.5mg)	-
铬 (Cr)	1000PPM	金属部品ND	$P = ND < X$
		非金属部品 <500ppm	$P \leq 350 < X$
多溴联苯PBB (Poly Brominated Biphenyls)	1000PPM	ND	-
多溴二苯醚PBDE (Poly brominated Di-phenyl Ethers)	1000PPM	ND	-
氯及氯化物	-	900PPM	$P \leq 630 < X < 1170ppm \leq F$
溴及溴化合物	-	900PPM	$P \leq 630 < X < 1170ppm \leq F$
氯及氯化物+溴及溴化合物	-	1500PPM	$P \leq 1050 < X < 1950ppm \leq F$
锑 (Sb)	-	700ppm	$P \leq 490 < X < 910ppm \leq F$

14.0 MECHANICAL OUTLINE DIMENSION

Figure 5. TFT-LCD FOG Outline Dimension

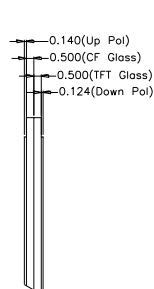
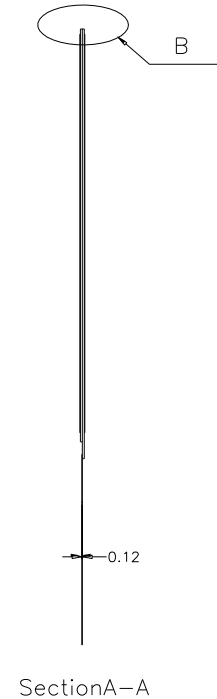
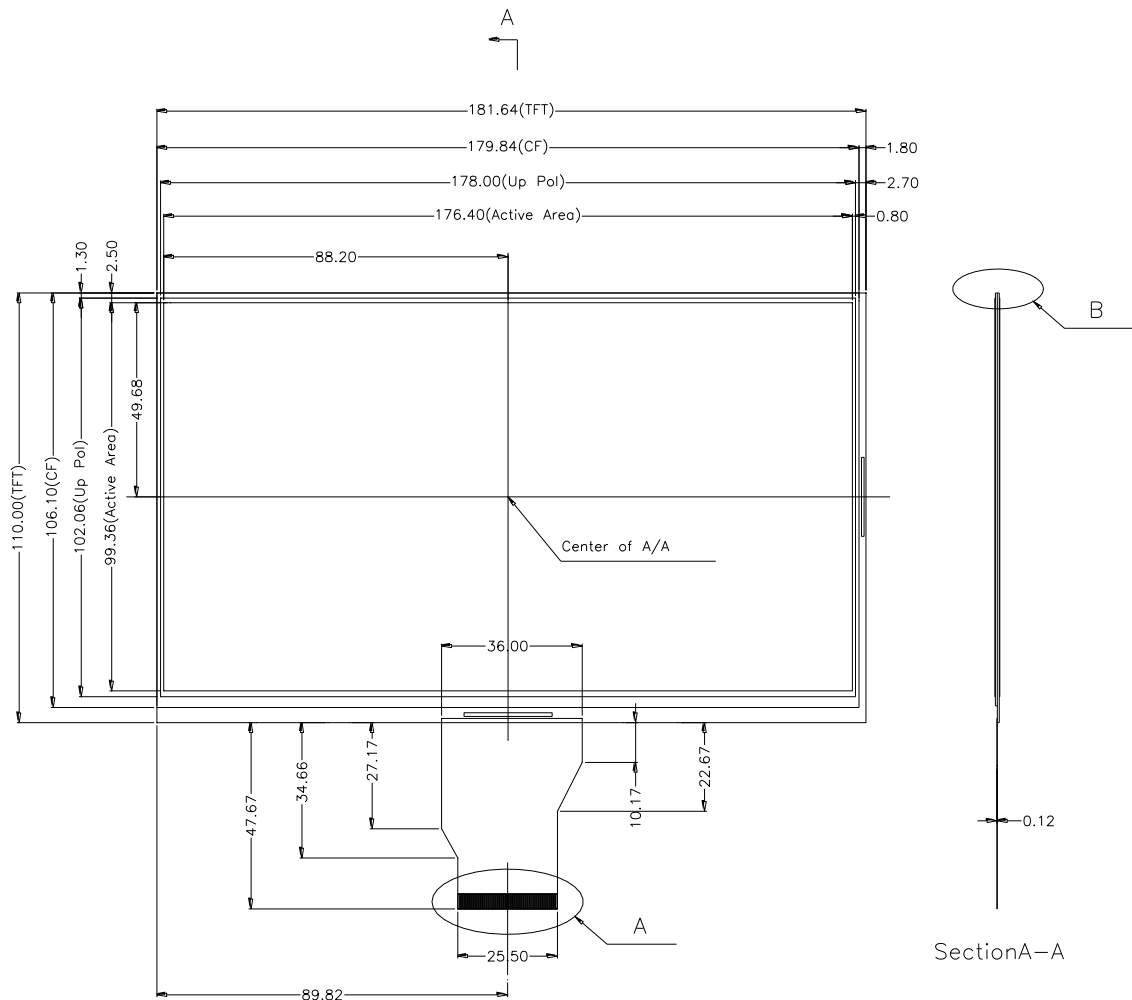

DETAIL B
SCALE 5:1

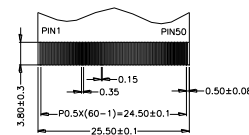

DETAIL A
SCALE 2:1

Figure 6. TFT-LCD FOG Outline Dimensions (Rear view)

