

PROPRIETARY NOTE

THIS SPECIFICATION IS THE PROPERTY OF BOE BJ AND SHALL NOT BE REPRODUCED OR COPIED WITHOUT THE WRITTEN PERMISSION OF BOE BJ AND MUST BE RETURNED TO BOE BJ UPON ITS REQUEST



SPEC. NUMBER

PRODUCT GROUP

Rev.

ISSUE DATE

PAGE

TLCM

P5

2016.04.19

1 OF 37

TV108FHM-AD0

Product Specification

Rev. P5

BEIJING BOE OPTOELECTRONICS TECHNOLOGY CO.,LTD

PRODUCT GROUP

REV

ISSUE DATE



TLCM PRODUCT

P5

2016.04.19

SPEC. NUMBER

SPEC. TITLE

TV108FHM-AD0-1B10 Preliminary Product Specification

PAGE

2 OF 37

REVISION HISTORY

REV.	ECN No.	DESCRIPTION OF CHANGES	DATE	PREPARED
P0	-	Initial Release	2014.12.16	谢建云
P1	-	Surface Treatment change ASF->AS Coating Packing design update	2015.03.25	谢建云
P2	-	PPID Label update OGS Electrical characteristics update	2015.04.28	谢建云
P3	-	Power Sequence update	2015.07.15	谢建云
P4	-	EDID Table Review	2015.10.20	李伟
P5	-	Change LCD & TS PPID label position	2016.04.19	陈会顺

Contents

No.	Items	Page
	REVISION HISTORY	2
	CONTENTS	3
1.0	General Description	4
2.0	Absolute Maximum ratings	6
3.0	Electrical specifications.	7
4.0	Optical specifications.	10
5.0	Interface Connection	15
6.0	Signal Timing Specification	18
7.0	Input Signals, Display Colors & Gray Scale of Colors	20
8.0	Power Sequence	21
9.0	Connector description	22
10.0	Reliability Test	24
11.0	Handling & Cautions.	24
12.0	Label	25
13.0	Packing information	27
14.0	Mechanical Outline Dimension	28
15.0	EDID Table	30

1.0 General Description

1.1 Application

- Tablet PC With Touch function

1.2 General Specification

1.2.1.General Total Solution Specification(Table 1.)

<Table 1. General Specifications>

Parameter	Specification	Unit	Remarks
Active area	239.04(H) × 134.46(V)	mm	
Number of pixels	1920 (H) × 1080(V)	pixels	
Pixel pitch	0.1245 (H) X 0.1245(V)	mm	
Pixel arrangement	RGB Vertical stripe		
Display colors	16.7M	colors	
Display mode	Normally Black		
Dimensional outline	275.14(H)*171.86(V) *3.45(Max) (W/PCB)	mm	
Weight	155(max) (without OGS) 255(max) (with OGS)	g	
Back-light	Lower Down side, 1-LED Lighting Bar type		Note 1
Power consumption	P _D : 1.15 (max)	W	
	P _{BL} :2.45(max)	W	
	P _{total} :3.6(max)	W	

Notes : 1. LED Lighting Bar (42*LED Array)

1.2 .2. Mechanical Characteristics(Table 2.)

<Table 2. Mechanical Characteristics>

Parameter	Specification	Unit	Remarks
TP Technology	PCT	-	
Touch Structure	OGS		
OGS Overall Size	X:275.14±0.1/Y2:171.86±0.1	[mm]	
TP View Area	X:240.64 Y:136.06	[mm]	
TP Active Area	X:242.04 Y:137.46	[mm]	
Total Thickness	3.45Max(W/O PCB)	[mm]	
Surface Hardness	7H	-	
Surface Treatment	ASF	-	
OGS Sensor Thickness	0.7	[mm]	
Bonding Mode	Directing Bonding	-	
ASF (Anti-Split Film)	No		
Anti-Water	No		
Transmittance	≥90%	%	
Strength	500	Mpa	

1.2 .3.Electrical characteristics(Table 3.)

<Table 2. Electrical characteristics>

Parameter	Specification	Unit	Remarks
TP Technology	PCT	-	
Touch Structure	OGS		
System OS	Windows		
Control Board Form	PCBA	-	
Control Board Thickness	Max1.9 (PCB+ Component Area+ Adhesive)	[mm]	
Type of Master IC	W9006		
Number of Tx / Rx	35/61		
VDD	3.3	[V]	
Touch Points (min)	10	-	
Auto Calibration	Yes		
Power Consumption (max.)	0.1	[Watts]	

2.0 ABSOLUTE MAXIMUM RATINGS

The followings are maximum values which, if exceed, may cause faulty operation or damage to the unit. The operational and non-operational maximum voltage and current values are listed in Table 2.

< Table 2. Absolute Maximum Ratings >

Ta=25+/-2°C

Parameter	Symbol	Min.	Max.	Unit	Remarks
Power Supply Voltage	V _{DD}	3.0	3.6	V	Note 1
Operating Temperature	T _{OP}	0	40	°C	Note 2
Storage Temperature	T _{ST}	-20	60	°C	

- Notes :
- Permanent damage to the device may occur if maximum values are exceeded functional operation should be restricted to the condition described under normal operating conditions.
 - Temperature and relative humidity range are shown in the figure below.
 90% RH Max. (40 °C ≥ Ta)
 Maximum wet - bulb temperature at 39 °C or less. (Ta > 40 °C) No condensation.

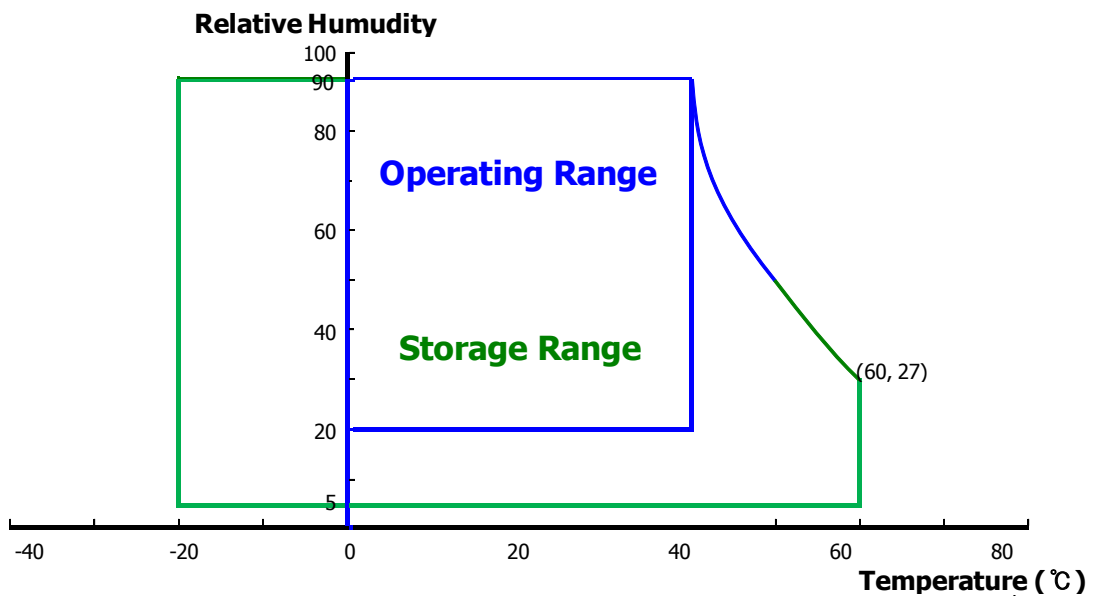

3.0 ELECTRICAL SPECIFICATIONS**3.1 Electrical Specifications**

< Table 3. Electrical specifications >

Ta=25+/-2°C

Parameter		Min.	Typ.	Max.	Unit	Remarks
Power Supply Voltage	V _{DD}	3.0	3.3	3.6	V	Note 1
Permissible Input Ripple Voltage	V _{RF}	-	-	100	mV	At V _{DD} = 3.3V
Power Supply Current	I _{DD}	-	300	750	mA	Note 1
Differential Input Voltage	V _{ID}	200	-	1000	mV	
Power Consumption	P _D	-	-	1.15	W	Note 1
	P _{BL}	-	-	2.45	W	Note 2
	P _{total}	-	-	3.6	W	

Notes : 1. The supply voltage is measured and specified at the interface connector of LCM.

The current draw and power consumption specified is for 3.3V at 25°C.

a) Typ : Mosaic Pattern (8X8)

b) Max : H-line 255

2. Calculated value for reference (V_{LED} × I_{LED})

3.2 Backlight Unit

< Table 4. LED Driving guideline specifications >

Ta=25+/-2°C

Parameter		Min.	Typ.	Max.	Unit	Remarks
LED Forward Voltage	V _F	-	-	3.0	V	-
LED Forward Current	I _F	-	19	-	mA	-
LED Power Consumption	P _{LED}		-	2.45	W	
LED Life-Time	N/A	15,000	-	-	Hour	I _F = 20mA Note 1
Power supply voltage for LED Driver	V _{LED}	-	-	21	V	

Notes :The LED Life-time define as the estimated time to 50% degradation of initial luminous.

3.3 LED structure

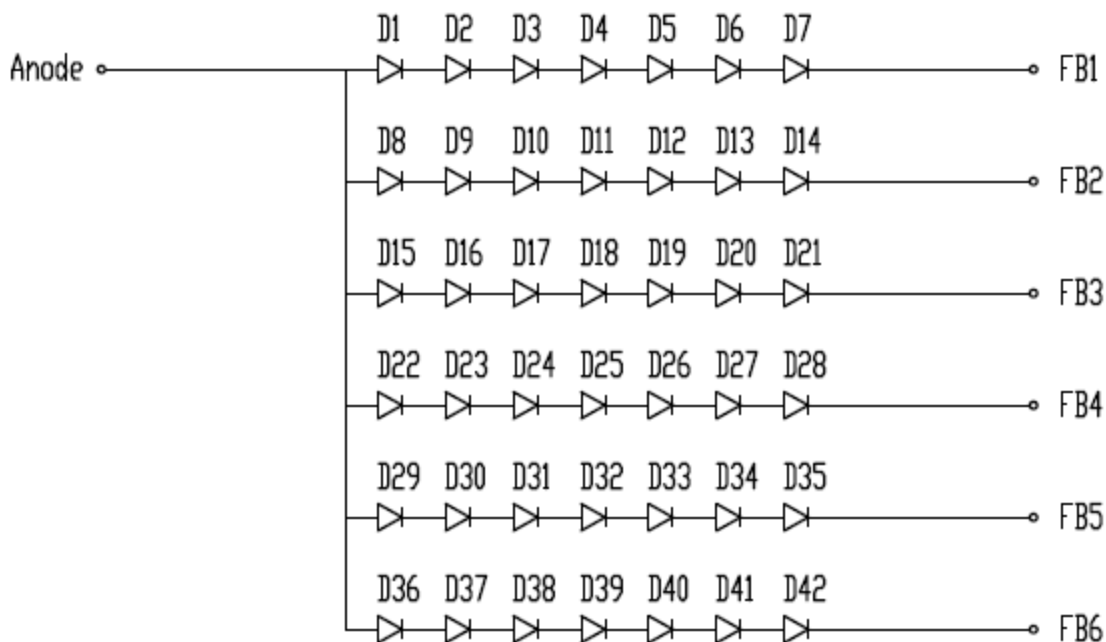

4.0 OPTICAL SPECIFICATION

4.1 Overview

The test of Optical specifications shall be measured in a dark room (ambient luminance ≤ 1 lux and temperature = $25\pm 2^{\circ}\text{C}$) with the equipment of Luminance meter system (Goniometer system and TOPCON BM-5) and test unit shall be located at an approximate distance 50cm from the LCD surface at a viewing angle of θ and Φ equal to 0° . We refer to $\theta\Phi=0$ ($=\theta 3$) as the 3 o'clock direction (the "right"), $\theta\Phi=90$ ($=\theta 12$) as the 12 o'clock direction ("upward"), $\theta\Phi=180$ ($=\theta 9$) as the 9 o'clock direction ("left") and $\theta\Phi=270$ ($=\theta 6$) as the 6 o'clock direction ("bottom"). While scanning θ and/or Φ , the center of the measuring spot on the Display surface shall stay fixed. The backlight should be operating for 30 minutes prior to measurement. VDD shall be $3.3\pm 0.3\text{V}$ at 25°C .

4.2 Optical Specifications

<Table 5. Optical Specifications>

Parameter		Symbol	Condition	Min.	Typ.	Max.	Unit	Remark
Viewing Angle range	Horizontal	Θ_3	CR > 10	80	-	-	Deg.	Note 1
		Θ_9		80	-	-	Deg.	
	Vertical	Θ_{12}		80	-	-	Deg.	
		Θ_6		80	-	-	Deg.	
Luminance Contrast ratio		CR	$\Theta = 0^{\circ}$	800	1000			Note 2
Luminance of White	5 Points	Y_w	$\Theta = 0^{\circ}$ I _{LED} = 19mA	340	400	-	cd/m ²	Note 3
White Luminance uniformity	5 Points	$\Delta Y5$		-	-	20%		Note 4
	13 Points	$\Delta Y13$		-	-	35%		
White Chromaticity		x_w	$\Theta = 0^{\circ}$	0.283	0.313	0.343		Note 5
		y_w		0.299	0.329	0.359		
Reproduction of color	Red	x_R	$\Theta = 0^{\circ}$	-0.03	0.633	+0.03		
		y_R			0.344			
	Green	x_G			0.334			
		y_G			0.631			
	Blue	x_B			0.158			
		y_B			0.038			
Gamut				68	72		%	
Response Time (Rising + Falling)		T_{RT}	Ta = 25°C $\Theta = 0^{\circ}$	-	16	25	ms	Note 6
Cross Talk		CT	$\Theta = 0^{\circ}$	-	-	2.0	%	Note 7

PRODUCT GROUP		REV	ISSUE DATE	BOE
TLCM PRODUCT		P5	2016.04.19	
SPEC. NUMBER	SPEC. TITLE			PAGE
	TV108FHM-AD0-1B10 Preliminary Product Specification			12 OF 37

Notes :

1. Viewing angle is the angle at which the contrast ratio is greater than 10. The viewing angles are determined for the horizontal or 3, 9 o'clock direction and the vertical or 6, 12 o'clock direction with respect to the optical axis which is normal to the LCD surface (see FIGURE 1).

2. Contrast measurements shall be made at viewing angle of $\Theta = 0$ and at the center of the LCD surface. Luminance shall be measured with all pixels in the view field set first to white, then to the dark (black) state .
(see FIGURE 1) Luminance Contrast Ratio (CR) is defined mathematically.

$$CR = \frac{\text{Luminance when displaying a white raster}}{\text{Luminance when displaying a black raster}}$$

3. Center Luminance of white is defined as luminance values of 5 point average across the LCD surface. Luminance shall be measured with all pixels in the view field set first to white. The Luminance will decrease to 90% after OGS bonding .This measurement shall be taken at the locations shown in FIGURE 2 for a total of the measurements per display.

4. The White luminance uniformity on LCD surface is then expressed as : $\Delta Y13 = 1 - \text{Minimum Luminance of 13 points} / \text{Maximum Luminance of 13 points}$
(see FIGURE 2 and FIGURE 3).

5. The color chromaticity coordinates specified in Table 5 shall be calculated from the spectral data measured with all pixels first in red, green, blue and white. Measurements shall be made at the center of the panel.

6. The electro-optical response time measurements shall be made as FIGURE 4 by switching the "data" input signal ON and OFF. The times needed for the luminance to change from 10% to 90% is T_r , and 90% to 10% is T_d .

7. Cross-Talk of one area of the LCD surface by another shall be measured by comparing the luminance (YA) of a 25mm diameter area, with all display pixels set to a gray level, to the luminance (YB) of that same area when any adjacent area is driven dark.
(See FIGURE 5).

PRODUCT GROUP		REV	ISSUE DATE	BOE
TLCM PRODUCT		P5	2016.04.19	
SPEC. NUMBER	SPEC. TITLE			PAGE
	TV108FHM-AD0-1B10 Preliminary Product Specification			13 OF 37

4.3 Optical measurements

Figure 1. Measurement Set Up

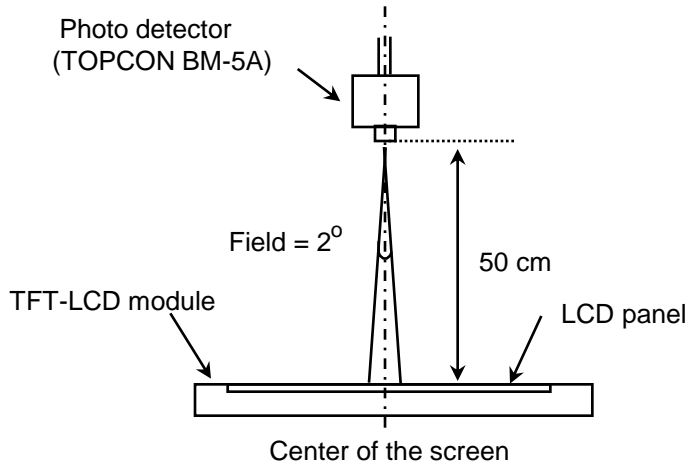

Optical characteristics measurement setup

Figure 2. White Luminance and Uniformity Measurement Locations (5 points)

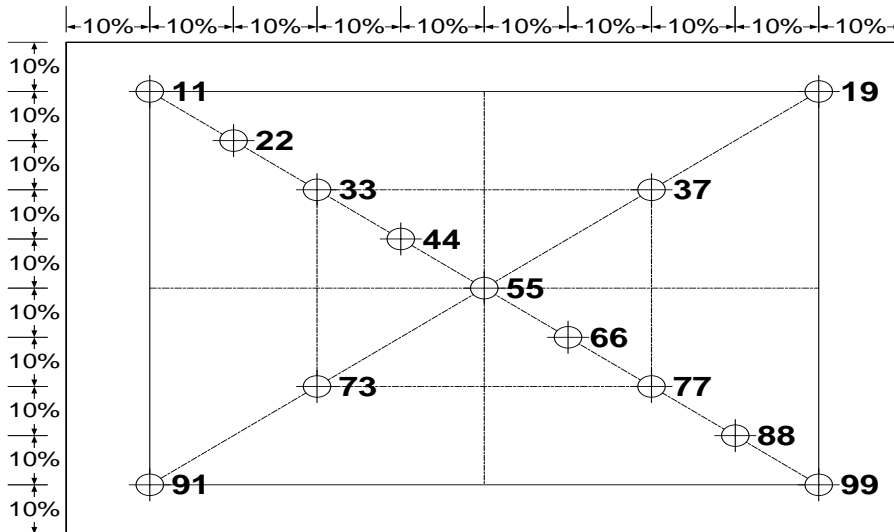

Center Luminance of white is defined as luminance values of center 5 points (33,37,55,73,77) across the LCD surface. Luminance shall be measured with all pixels in the view field set first to white. This measurement shall be taken at the locations shown in FIGURE 2 for a total of the measurements per display.

PRODUCT GROUP		REV	ISSUE DATE	BOE
TLCM PRODUCT		P5	2016.04.19	
SPEC. NUMBER	SPEC. TITLE			PAGE
	TV108FHM-AD0-1B10 Preliminary Product Specification			14 OF 37

Figure 3. Uniformity Measurement Locations (13 points)

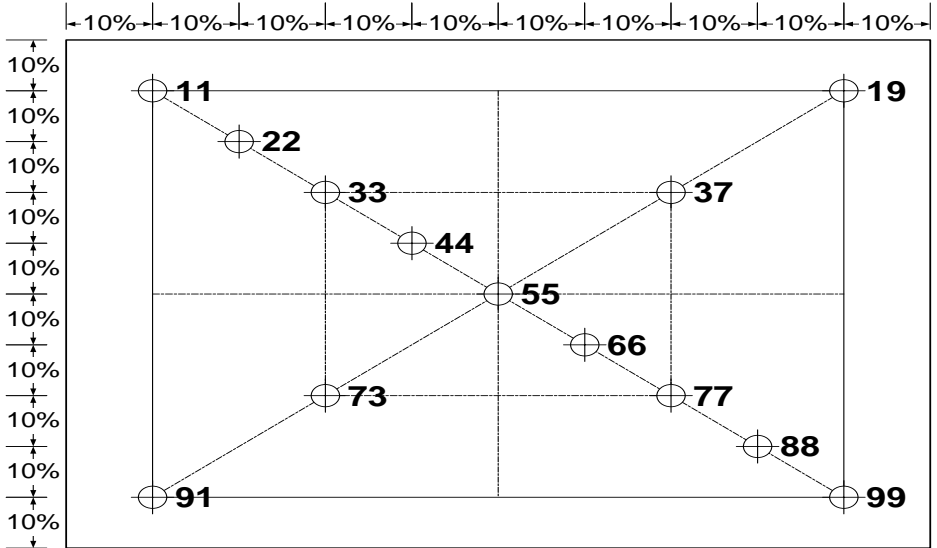

The White luminance uniformity on LCD surface is then expressed as : $\Delta Y_5 = 1 - \text{Minimum Luminance of five points} / \text{Maximum Luminance of five points}$ (see FIGURE 2) , $\Delta Y_{13} = 1 - \text{Minimum Luminance of 13 points} / \text{Maximum Luminance of 13 points}$ (see FIGURE 3).

Figure 4. Response Time Testing

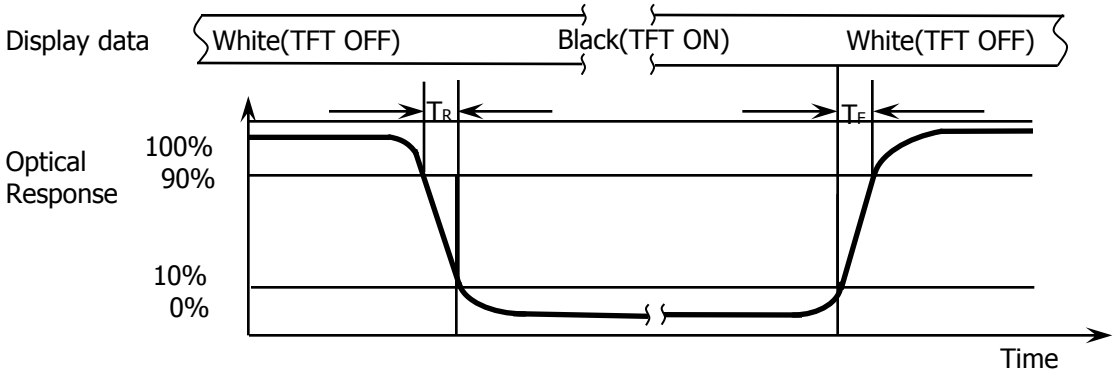

The electro-optical response time measurements shall be made as shown in FIGURE 4 by switching the “data” input signal ON and OFF. The times needed for the luminance to change from 10% to 90% is T_d and 90% to 10% is T_r .

Figure 5. Cross Modulation Test Description

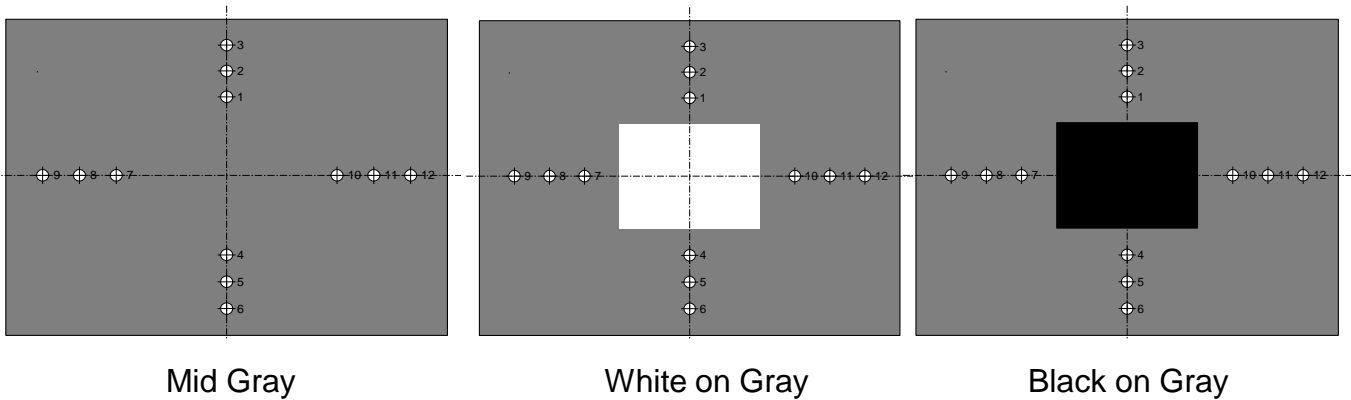

$$\text{CrossTalk}_{\text{WonG}} = (L_{\text{WonG}} - L_{\text{Gray}}) / L_{\text{Gray}} * 100\%$$

$$\text{CrossTalk}_{\text{BonG}} = (L_{\text{BonG}} - L_{\text{Gray}}) / L_{\text{Gray}} * 100\%$$

Where:

L_{Gray} = the luminance of full mid gray screen at that point (cd/m²)

$L_{\text{WonG or BonG}}$ = Subsequent luminance of that point with the white box displayed or with the black box displayed (cd/m²)

The location measured will be exactly the same in both patterns

Point	x	y
1	0	3/12 h
2	0	4/12 h
3	0	5/12 h
4	0	-3/12 h
5	0	-4/12 h
6	0	-5/12 h
7	-3/12 w	0
8	-4/12 w	0
9	-5/12 w	0
10	0	3/12 w
11	0	4/12 w
12	0	5/12 w

Calculate shadowing for each point by comparing the luminance of full mid gray screen at that point to the luminance of the same point with the white box displayed and to the luminance of the same point with the black box displayed. (Refer to FIGURE 5).

5.0 INTERFACE CONNECTION.**5.1 Electrical Interface Connection**

The electronics interface connector is I-PEX 20584-045E-01 or Compatible.

The connector interface pin assignments are listed in Table 6.

<Table 6. Pin Assignments for the Interface Connector>

Terminal	Symbol	Functions
1	NC	Reserved for LCD manufacturer's use
2	Panel detect	loop pin #44
3	H_GND	High Speed Ground
4	Lane1_N	Complement Signal Link Lane 1
5	NC	Reserved for LCD manufacturer's use
6	Lane1_P	True Signal Link Lane 1
7	H_GND	High Speed Ground
8	Lane0_N	Complement Signal Link Lane 0
9	NC	Reserved for LCD manufacturer's use
10	Lane0_P	True Signal Link Lane 0
11	H_GND	High Speed Ground
12	AUX_CH_P	True Signal Auxiliary Channel
13	NC	Reserved for LCD manufacturer's use
14	AUX_CH_N	Complement Signal Auxiliary Channel
15	H_GND	High Speed Ground
16	Hsync	Hsync Out signal pin
17	H_GND	High Speed Ground
18	HPD	HPD signal pin
19	VDD	LCD logic and driver power(3.3V)
20	VDD	LCD logic and driver power(3.3V)
21	VDD	LCD logic and driver power(3.3V)
22	VDD	LCD logic and driver power(3.3V)
23	VDD	LCD logic and driver power(3.3V)

5.0 INTERFACE CONNECTION.

5.1 Electrical Interface Connection

The electronics interface connector is I-PEX 20584-045E-01 or Compatible.
The connector interface pin assignments are listed in Table 6.

<Table 6. Pin Assignments for the Interface Connector>

Pin No.	Symbol	Description
24	BIST	LCD Panel Self Test Enable
25	LCD_GND	LCD logic and driver ground
26	LCD_GND	LCD logic and driver ground
27	LCD_GND	LCD logic and driver ground
28	LCD_GND	LCD logic and driver ground
29	LCD_GND	LCD logic and driver ground
30	LCD_GND	LCD logic and driver ground
31	NC	Reserved for LCD manufacturer's use
32	VLED	VLED_FB1
33	VLED	VLED_FB2
34	VLED	VLED_FB3
35	VLED	VLED_FB4
36	VLED	VLED_FB5
37	VLED	VLED_FB6
38	NC	Reserved for LCD manufacturer's use
39	VBL	Backlight power
40	VBL	Backlight power
41	VBL	Backlight power
42	VBL	Backlight power
43	NC	Reserved for LCD manufacturer's use
44	Panel detect	loop pin #02
45	NC	Reserved for LCD manufacturer's use

5-2. eDP Interface

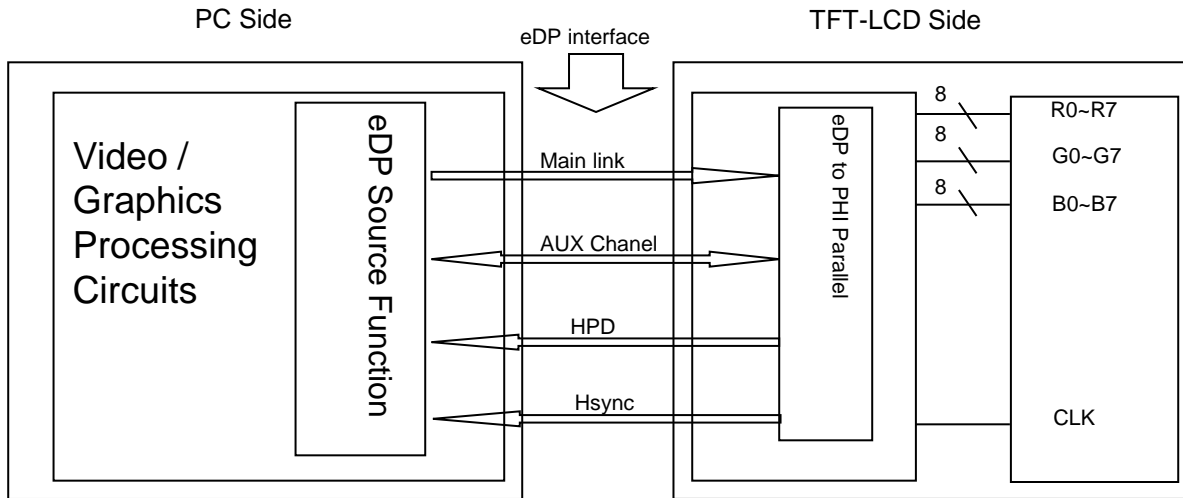

Note. Transmitter : NT71392 or equivalent.

5.3.eDP Input signal

Lane 0	Lane 1
R0-7:0	R1-7:0
G0-7:0	G1-7:0
B0-7:0	B1-7:0
R2-7:0	R3-7:0
G2-7:0	G3-7:0
B2-7:0	B3-7:0
R4-7:0	R5-7:0
G4-7:0	G5-7:0
B4-7:0	B5-7:0

eDP 2lane 8 bit Input data mapping

5.4 Back-light & LCM Interface Connection

Interface Connector: UJU PF040-B09B-C09

<Table 7. Pin Assignments for the BLU & LCM Connector>

Pin No.	Symbol	Description	Pin No.	Symbol	Description
1	VBL	LED anode connection	6	FB4	LED cathode connection
2	VBL	LED anode connection	7	FB3	LED cathode connection
3	VBL	LED anode connection	8	FB2	LED cathode connection
4	FB6	LED cathode connection	9	FB1	LED cathode connection
5	FB5	LED cathode connection			

5.5 TP Interface Connection

PIN	1	2-4	5-6	7-41	42-43	44-45
Function	Dum	ID1-3	GND	Tx1-Tx35	Guard	GND
46-106	46-106	107-108	109-110	111-145	146-147	148-151
Function	Rx1-Rx61	GND	Guard	Tx35-Tx1	GND	Dum

6.0 SIGNAL TIMING SPECIFICATION

6.1 The TV108FHM-AD0 is operated by the DE only.

Item		Symbols	Min	Typ	Max	Unit
Clock	Frequency	1/Tc	100	140	-	MHz
	High Time	Tch	-	4/7	-	Tc
	Low Time	Tcl	-	3/7	-	Tc
Frame Period		Tv	1112	1120	1180	lines
			-	60	-	Hz
			-	16.7	-	ms
Vertical Display Period		Tvd	-	1080	-	lines
One line Scanning Period		Th	2020	2080	2400	clocks
Horizontal Display Period		Thd	-	1920	-	clocks

6.2 eDP Rx Interface Timing Parameter

The specification of the eDP Rx interface timing parameter is shown in Table 8.

<Table 8. eDP Rx Interface Timing Specification>

Item	Symbol	Min	Typ	Max	Unit	Remark
Link clock down spreading	Down_Spread_Amplitude	0	-	0.5	%	
Differential peak-to-peak input voltage at package pins	VRX-DIFFp-p	120	-	1200	mV	
Rx input DC common mode voltage	VRX_DC_CM	0	-	2.0	V	
Differential termination resistance	RRX-TERM	-	100	-	Ω	
Rx short circuit current limit	IRX_SHORT	-	-	50	mA	
Intra-pair skew at Rx package pins	LRX_SKEW_INTRA_PAIR	-	-	300	ps	

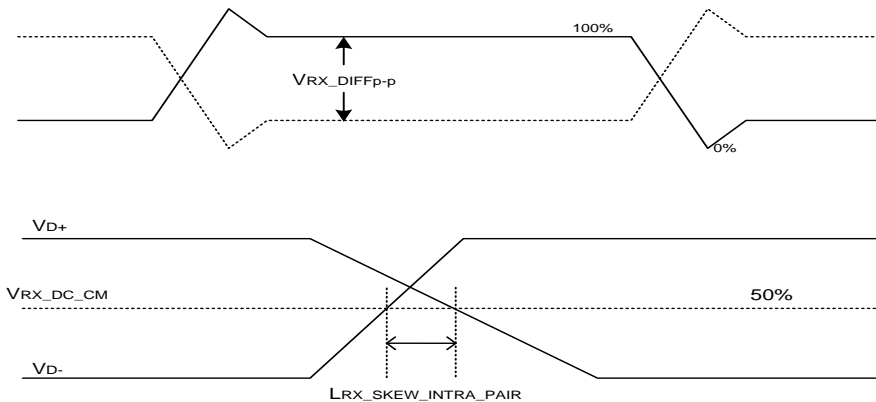

7.0 INPUT SIGNALS, BASIC DISPLAY COLORS & GRAY SCALE OF COLORS

	Colors & Gray scale	Data signal																							
		R0	R1	R2	R3	R4	R5	R6	R7	G0	G1	G2	G3	G4	G5	G6	G7	B0	B1	B2	B3	B4	B5	B6	B7
Basic colors	Black	0	0	0	0	0	0	0	0	0	0	0	0	0	0	0	0	0	0	0	0	0	0	0	0
	Blue	0	0	0	0	0	0	0	0	0	0	0	0	0	0	0	0	1	1	1	1	1	1	1	1
	Green	0	0	0	0	0	0	0	0	1	1	1	1	1	1	1	1	0	0	0	0	0	0	0	0
	Light Blue	0	0	0	0	0	0	0	0	1	1	1	1	1	1	1	1	1	1	1	1	1	1	1	1
	Red	1	1	1	1	1	1	1	1	0	0	0	0	0	0	0	0	0	0	0	0	0	0	0	0
	Purple	1	1	1	1	1	1	1	1	0	0	0	0	0	0	0	0	1	1	1	1	1	1	1	1
	Yellow	1	1	1	1	1	1	1	1	1	1	1	1	1	1	1	1	0	0	0	0	0	0	0	0
	White	1	1	1	1	1	1	1	1	1	1	1	1	1	1	1	1	1	1	1	1	1	1	1	1
Gray scale of Red	Black	0	0	0	0	0	0	0	0	0	0	0	0	0	0	0	0	0	0	0	0	0	0	0	
	△	1	0	0	0	0	0	0	0	0	0	0	0	0	0	0	0	0	0	0	0	0	0	0	
	Darker	0	1	0	0	0	0	0	0	0	0	0	0	0	0	0	0	0	0	0	0	0	0	0	
	△																								
	▽																								
	Brighter	1	0	1	1	1	1	1	1	0	0	0	0	0	0	0	0	0	0	0	0	0	0	0	0
	▽	0	1	1	1	1	1	1	1	0	0	0	0	0	0	0	0	0	0	0	0	0	0	0	0
Red	1	1	1	1	1	1	1	1	0	0	0	0	0	0	0	0	0	0	0	0	0	0	0	0	
Gray scale of Green	Black	0	0	0	0	0	0	0	0	0	0	0	0	0	0	0	0	0	0	0	0	0	0	0	
	△	0	0	0	0	0	0	0	0	1	0	0	0	0	0	0	0	0	0	0	0	0	0	0	
	Darker	0	0	0	0	0	0	0	0	0	1	0	0	0	0	0	0	0	0	0	0	0	0	0	
	△																								
	▽																								
	Brighter	0	0	0	0	0	0	0	0	1	0	1	1	1	1	1	1	0	0	0	0	0	0	0	0
	▽	0	0	0	0	0	0	0	0	0	1	1	1	1	1	1	1	0	0	0	0	0	0	0	0
Red	0	0	0	0	0	0	0	0	1	1	1	1	1	1	1	1	0	0	0	0	0	0	0	0	
Gray scale of Blue	Black	0	0	0	0	0	0	0	0	0	0	0	0	0	0	0	0	0	0	0	0	0	0	0	
	△	0	0	0	0	0	0	0	0	0	0	0	0	0	0	0	0	1	0	0	0	0	0	0	
	Darker	0	0	0	0	0	0	0	0	0	0	0	0	0	0	0	0	0	1	0	0	0	0	0	
	△																								
	▽																								
	Brighter	0	0	0	0	0	0	0	0	0	0	0	0	0	0	0	0	1	0	1	1	1	1	1	1
	▽	0	0	0	0	0	0	0	0	0	0	0	0	0	0	0	0	0	1	1	1	1	1	1	1
Red	0	0	0	0	0	0	0	0	0	0	0	0	0	0	0	0	1	1	1	1	1	1	1	1	
Gray scale of White & Black	Black	0	0	0	0	0	0	0	0	0	0	0	0	0	0	0	0	0	0	0	0	0	0	0	
	△	1	0	0	0	0	0	0	0	1	0	0	0	0	0	0	0	1	0	0	0	0	0	0	
	Darker	0	1	0	0	0	0	0	0	0	1	0	0	0	0	0	0	0	1	0	0	0	0	0	
	△																								
	▽																								
	Brighter	1	0	1	1	1	1	1	1	1	0	1	1	1	1	1	1	1	0	1	1	1	1	1	1
	▽	0	1	1	1	1	1	1	1	0	1	1	1	1	1	1	1	0	1	1	1	1	1	1	1
White	1	1	1	1	1	1	1	1	1	1	1	1	1	1	1	1	1	1	1	1	1	1	1	1	

8.0 POWER SEQUENCE

To prevent a latch-up or DC operation of the LCD module, the power on/off sequence shall be as shown in below

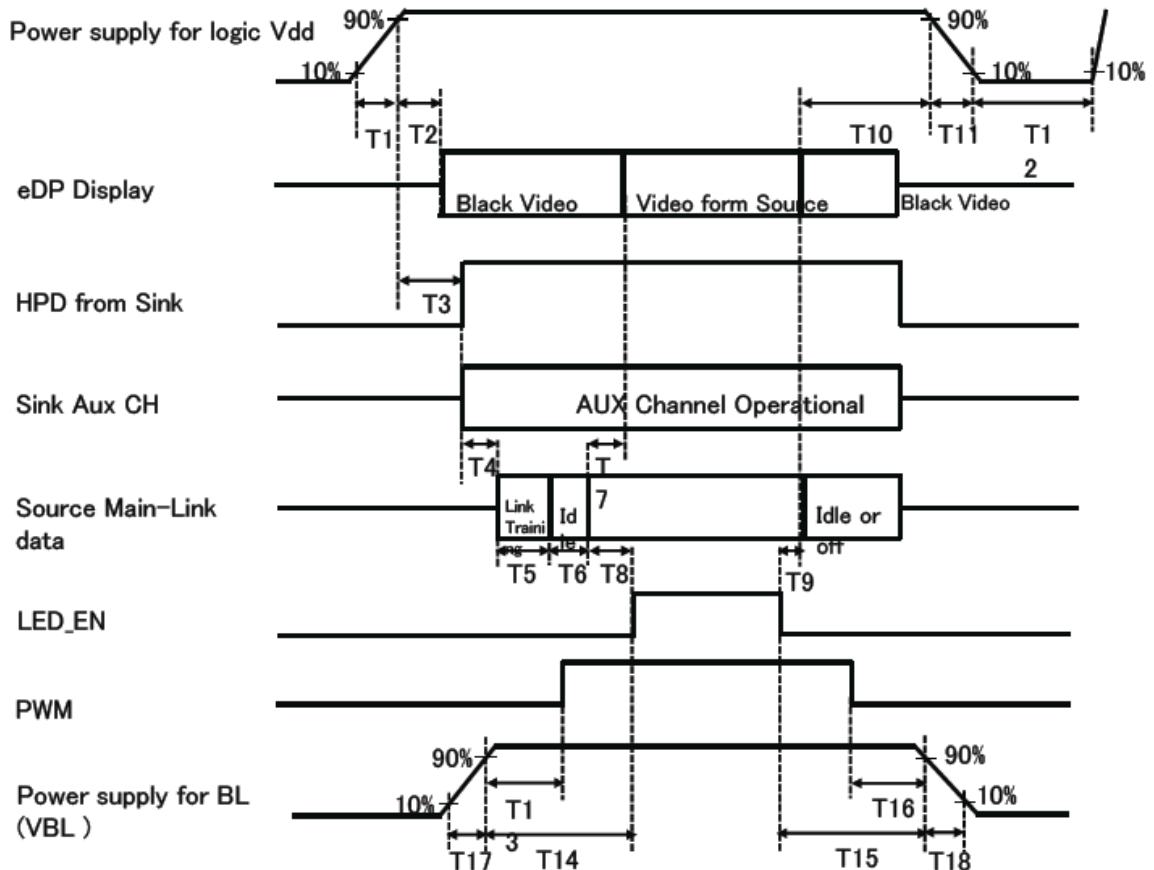

- 0.5ms ≤ T1 ≤ 10 ms
- 0ms ≤ T2 ≤ 200 ms
- 0ms ≤ T3 ≤ 200 ms
- 50ms ≤ T8
- 0ms ≤ T13
- 0ms ≤ T14
- 0ms ≤ T17
- 0ms ≤ T7 ≤ 50 ms
- 0ms ≤ T10 ≤ 500 ms
- 0 ms ≤ T11 ≤ 10 ms
- 150ms ≤ T12
- 0ms ≤ T15
- 0ms ≤ T16
- 0ms ≤ T18

Notes:

1. When the power supply VDD is 0V, keep the level of input signals on the low or keep high impedance.
2. Do not keep the interface signal high impedance when power is on. Back Light must be turn on after power for logic and interface signal are valid.

9.0 Connector Description

Physical interface is described as for the connector on LCM.

These connectors are capable of accommodating the following signals and will be following components.

9.1 TFT LCD Module

Connector Name /Description	For Signal Connector
Manufacturer	STM or Compatible
Type/ Part Number	UJU PF040-B09B-C09 or Compatible
Mating housing/ Part Number	I-PEX 20584-045E-01 or Compatible

10.0 RELIABILITY TEST

The Reliability test items and its conditions are shown in below.

<Table 10. Reliability test>

No		Conditions
1	High temperature storage test	Ta = 60 °C, 240 hrs
2	Low temperature storage test	Ta = -20 °C, 240 hrs
3	High temperature & high humidity operation test	Ta = 50 °C, 90%RH, 240 hrs
4	High temperature operation test	Ta = 50 °C, 240 hrs
5	Low temperature operation test	Ta = 0 °C, 240 hrs
6	Thermal shock	Ta = -20 °C ↔ 60 °C (0.5 hr), 100 cycle
7	Power on/off	2s on/2s off 20000cycles
8	Vibration test (non-operating)	1.5G, 10~500Hz Sign X,Y,Z / Sweep rate : 0.5hour
9	Shock test (non-operating)	220G, Half Sine Wave 2msec ± X, ± Y, ± Z Once for each direction
10	Electro-static discharge test (non-operating)	Air : 150 pF, 330Ω, 15 KV Contact : 150 pF, 330Ω, 8 KV

11.0 HANDLING & CAUTIONS

(1) Cautions when taking out the module

- Pick the pouch only, when taking out module from a shipping package.

(2) Cautions for handling the module

- As the electrostatic discharges may break the LCD module, handle the LCD module with care. Peel a protection sheet off from the LCD panel surface as slowly as possible.
- As the LCD panel and back - light element are made from fragile glass material, impulse and pressure to the LCD module should be avoided.
- As the surface of the polarizer is very soft and easily scratched, use a soft dry cloth without chemicals for cleaning.
- Do not pull the interface connector in or out while the LCD module is operating.
- Put the module display side down on a flat horizontal plane.
- Handle connectors and cables with care.

(3) Cautions for the operation

- When the module is operating, do not lose CLK, ENAB signals. If any one of these signals is lost, the LCD panel would be damaged.
- Obey the supply voltage sequence. If wrong sequence is applied, the module would be damaged.

PRODUCT GROUP		REV	ISSUE DATE	BOE
TLCM PRODUCT		P5	2016.04.19	
SPEC. NUMBER	SPEC. TITLE			PAGE
	TV108FHM-AD0-1B10 Preliminary Product Specification			27 OF 37

- (4) Cautions for the atmosphere
- Dew drop atmosphere should be avoided.
 - Do not store and/or operate the LCD module in a high temperature and/or humidity atmosphere. Storage in an electro-conductive polymer packing pouch and under relatively low temperature atmosphere is recommended.
- (5) Cautions for the module characteristics
- Do not apply fixed pattern data signal to the LCD module at product aging.
 - Applying fixed pattern for a long time may cause image sticking.
- (6) Other cautions
- Do not disassemble and/or re-assemble LCD module.
 - Do not re-adjust variable resistor or switch etc.
 - When returning the module for repair or etc., Please pack the module not to be broken. We recommend to use the original shipping packages.

12.0 LABEL

(1) TTL label



TTL ID Naming Rule

序列号	1	2	3	4	5	6	7	8	9	10	11	12	13	14	15	16	17
代码	S	L	S	T	1	2	3	5	9	4	2	0	0	0	1	D	B
描述	GBN		等级	line	年	月	FG-Code后4位					Serial Number					

PRODUCT GROUP		REV	ISSUE DATE	BOE
TLCM PRODUCT		P5	2016.04.19	
SPEC. NUMBER	SPEC. TITLE			PAGE
	TV108FHM-AD0-1B10 Preliminary Product Specification			28 OF 37

(2) High voltage caution label

	<p>HIGH VOLTAGE CAUTION</p>	<p>COLD CATHODE FLUORESCENT LAMP IN LCD PANEL CONTAINS A SMALL AMOUNT OF MERCURY. PLEASE FOLLOW LOCAL ORDINANCES OR REGULATIONS FOR DISPOSAL.</p>
	<p>RISK OF ELECTRIC SHOCK. DISCONNECT THE ELECTRIC POWER BEFORE SERVICING</p>	

(3) Box label

BOE Technology Group Co., Ltd.

MODEL: **TV108FHM-AD0** ① QTY: **40** ②

SERIAL NO: **XXXXXXXXXXXX** ③ DATE: **20XX/XX/XX** ④

Box ID条形码



OYJOMP ⑤ **1B10** ⑥

序列号标注部分需打印, 说明如下:

- | | |
|-----------------------------|-------------------|
| 1. Top 12 of the FG-Code | 2. Total Quantity |
| 3. Box ID | 4. Packing Date |
| 5. 客户端段物料号(客户端)---暂不打印,预留空间 | |
| 6. Last 4 of the FG-Code | |
| 7. Vendor code---暂不打印, 预留空间 | |

Total Size:

序列号	1	2	3	4	5	6	7	8	9	10	11	12	13
代码	S	L	S	T	1	4	3	D	0	0	1	H	D
描述	GBN代码		等级	TM1	年份		月	Rev	Serial Number				

13.0 PACKING INFORMATION

13.1 Packing order

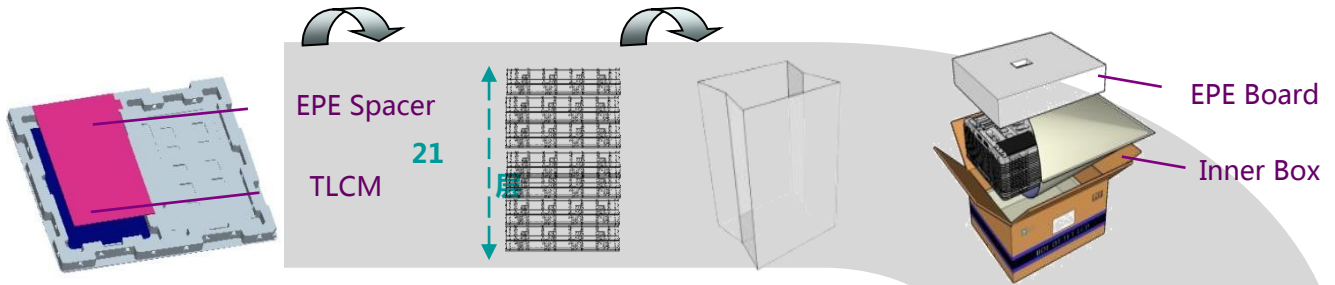

step 1

- Put 2pcs TLCM in the tray
- Put 2 pcs EPE Spacer on the TLCM
- Total: 2pcs/Tray

step 2

- Put 21ea PET Tray in the PE Bag
- Put PE Bag full of Products in the Box
- Total: 40pcs TLCM/Inner Box

step 4

- 双排双层码放
- 容量:44EA Pallet/Track,21120pcs TTL/Track

step 3

- Put Box on the Pallet ;
- 4ea Boxes/floor, 3 floors/Pallet, 12ea Box/Pallet ,
- Total height is 1015cm ;
- Total: 480pcs/Pallet

13.2 Notes

- Box Dimension:520mm*410mm*295mm
- Package Quantity in one Box:40pcs
- Total Weight: TBD

14.2 Total Solution Outline Dimension

Figure 7. Total Solution Outline Dimensions (Rear view)

Rear view

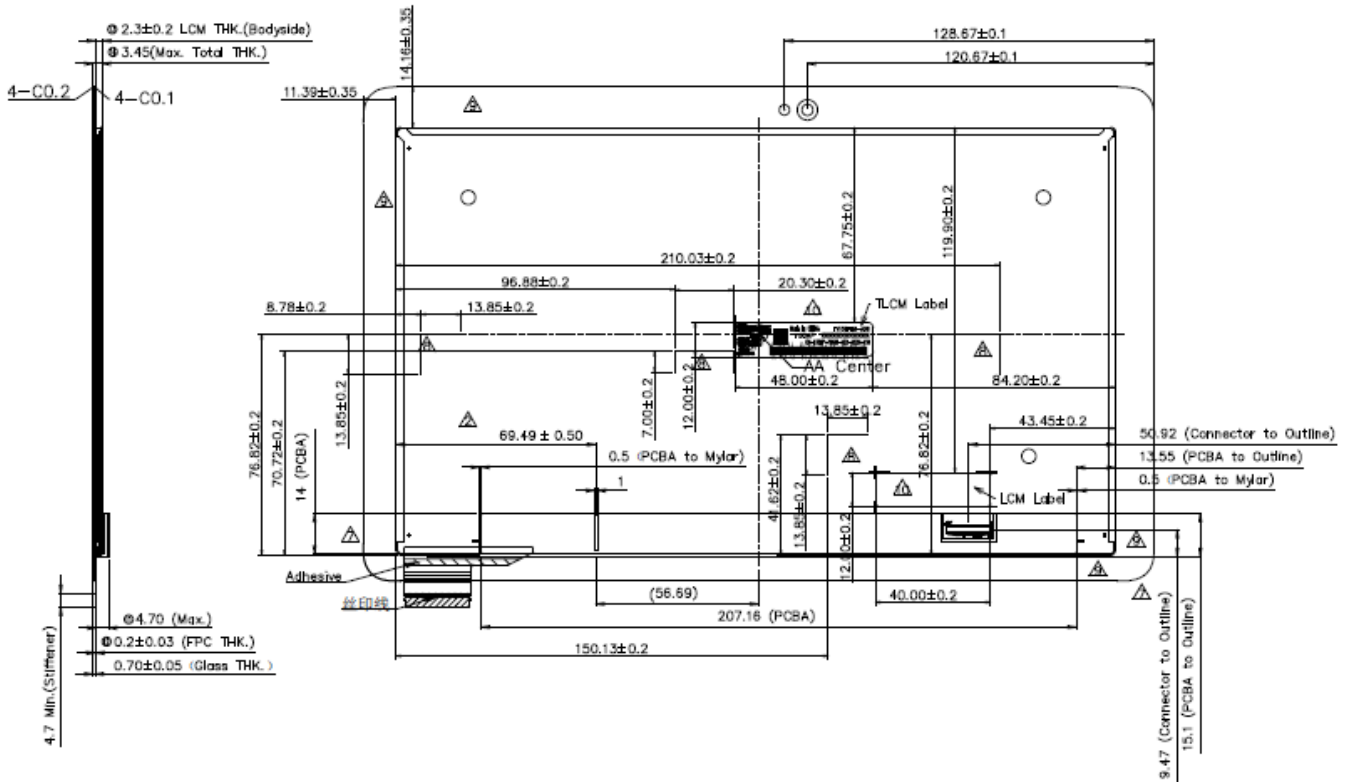

14.3 Touch Panel Outline Dimension

Figure 8. Touch Panel Outline Dimensions (Front view)

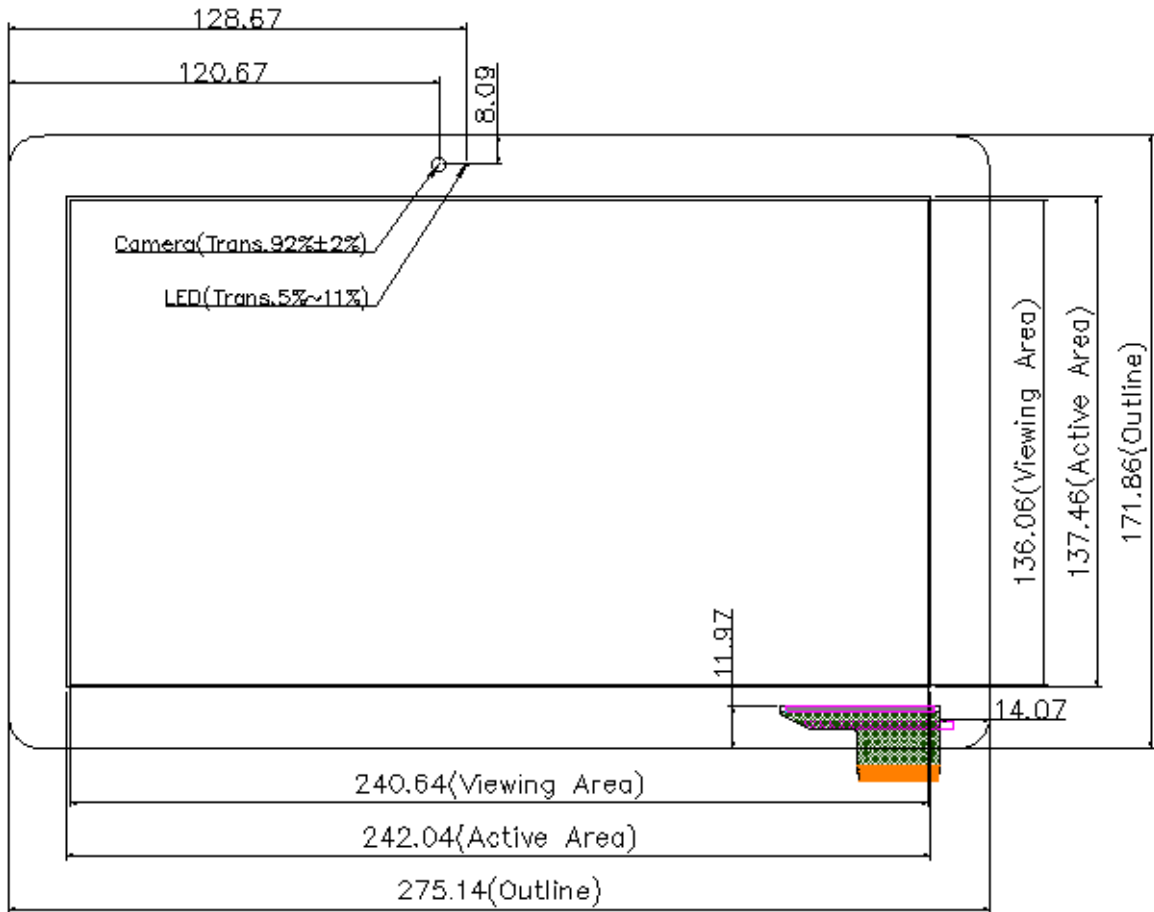

Note:

1. The drawing is a view from glass;
2. Glass surface treatment: ASF;
3. Rounded corner uses fillet(spline);
4. Tolerance of OD/VA/AA is $\pm 0.1\text{mm}$.

14.4 Touch Panel Outline Dimension

Figure 9. Touch Panel Outline Dimensions (Rear view)

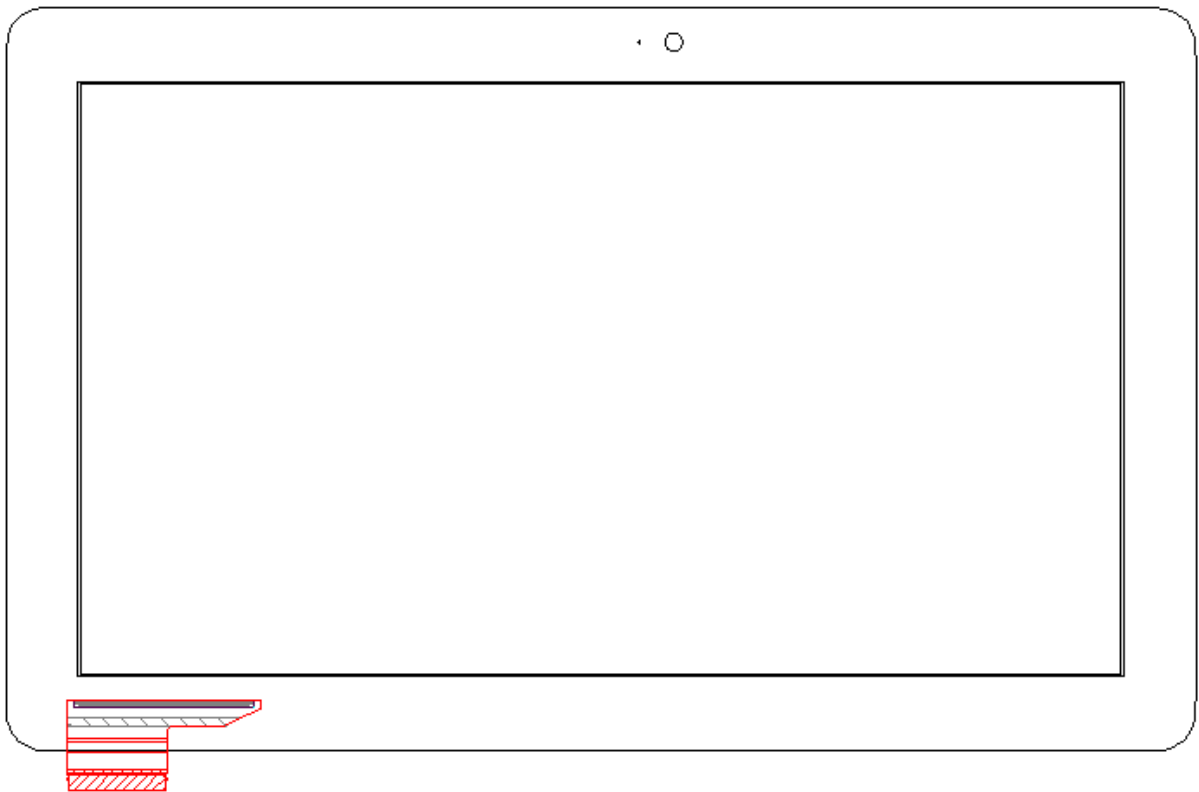

15.0 EDID Table

Address (HEX)	Function	Hex	Dec	crc	Input values.	Notes
00	Header	00	0		0	EDID Header
01		FF	255		255	
02		FF	255		255	
03		FF	255		255	
04		FF	255		255	
05		FF	255		255	
06		FF	255		255	
07		00	0		0	
08	ID Manufacturer Name	09	9		BOE	ID = BOE
09		E5	229			
0A	ID Product Code	57	87		1623	ID = 1623
0B		06	6			
0C	32-bit serial No.	00	0			
0D		00	0			
0E		00	0			
0F		00	0			
10	Week of manufacture	28	40		40	
11	Year of Manufacture	19	25		2015	Manufactured in 2015
12	EDID Structure Ver.	01	1		1	EDID Ver 1.0
13	EDID revision #	04	4		4	EDID Rev. 0.4
14	Video input definition	A5	165		-	
15	Max H image size	22	34		34	34 cm (Approx)
16	Max V image size	13	19		19	19 cm (Approx)
17	Display Gamma	78	120		2.2	Gamma curve = 2.2
18	Feature support	0A	10			RGB display, Preferred Timming mode
19	Red/Green low bits	7B	123		-	Red / Green Low Bits
1A	Blue/White low bits	7A	122		-	Blue / White Low Bits
1B	Red x high bits	A2	162	649	0.634	Red (x) = 10100010 (0.634)
1C	Red y high bits	57	87	351	0.343	Red (y) = 01010111 (0.343)
1D	Green x high bits	54	84	338	0.331	Green (x) = 01010100 (0.331)
1E	Green y high bits	A2	162	651	0.636	Green (y) = 10100010 (0.636)
1F	Blue x high bits	28	40	161	0.158	Blue (x) = 00101000 (0.158)
20	Blue y high bits	0C	12	51	0.05	Blue (y) = 00001100 (0.05)
21	White x high bits	4F	79	318	0.311	White (x) = 01001111 (0.311)
22	White y high bits	53	83	334	0.327	White (y) = 01010011 (0.327)
23	Established timing 1	00	0		-	

PRODUCT GROUP

REV

ISSUE DATE



TLCM PRODUCT

P5

2016.04.19

SPEC. NUMBER

SPEC. TITLE

TV108FHM-AD0-1B10 Preliminary Product Specification

PAGE

35 OF 37

24	Established timing 2	00	0	-		
25	Established timing 3	00	0	-		
26	Standard timing #1	01	1		Not Used	
27		01	1			
28	Standard timing #2	01	1		Not Used	
29		01	1			
2A	Standard timing #3	01	1		Not Used	
2B		01	1			
2C	Standard timing #4	01	1		Not Used	
2D		01	1			
2E	Standard timing #5	01	1		Not Used	
2F		01	1			
30	Standard timing #6	01	1		Not Used	
31		01	1			
32	Standard timing #7	01	1		Not Used	
33		01	1			
34	Standard timing #8	01	1		Not Used	
35		01	1			
36	Detailed timing/monitor descriptor #1	B0	176	140.00	140MHz Main clock	
37		36	54			
38		80	128	1920	Hor Active = 1920	
39		A0	160	160	Hor Blanking = 160	
3A		70	112	-	4 bits of Hor. Active + 4 bits of Hor. Blanking	
3B		38	56	1080	Ver Active = 1080	
3C		28	40	40	Ver Blanking = 40	
3D		40	64	-	4 bits of Ver. Active + 4 bits of Ver. Blanking	
3E		30	48	48	Hor Sync Offset = 48	
3F		20	32	32	H Sync Pulse Width = 32	
40		36	54	3	V sync Offset = 3 line	
41		00	0	6	V Sync Pulse width : 6 line	
42		58	88	344	Horizontal Image Size = 344 mm (Low 8 bits)	
43		C2	194	194	Vertical Image Size = 194 mm (Low 8 bits)	
44		10	16	-	4 bits of Hor Image Size + 4 bits of Ver Image Size	
45		00	0	0	Hor Border (pixels)	
46		00	0	0	Vertical Border (Lines)	
47		1A	26		Refer to right table	
48		Detailed timing/monitor descriptor #2	30	48	113.12	113.12MHz Main clock
49			2C	44		
4A	80		128	1920	Hor Active = 1920	
4B	A0		160	160	Hor Blanking = 160	
4C	70		112	-	4 bits of Hor. Active + 4 bits of Hor. Blanking	
4D	38		56	1080	Ver Active = 1080	
4E	28		40	40	Ver Blanking = 40	
4F	40		64	-	4 bits of Ver. Active + 4 bits of Ver. Blanking	
50	30		48	48	Hor Sync Offset = 48	
51	20		32	32	H Sync Pulse Width = 32	
52	36		54	3	V sync Offset = 3 line	
53	00		0	6	V Sync Pulse width : 6 line	
54	58		88	344	Horizontal Image Size = 344 mm (Low 8 bits)	
55	C2		194	194	Vertical Image Size = 194 mm (Low 8 bits)	
56	10		16	-	4 bits of Hor Image Size + 4 bits of Ver Image Size	
57	00		0	0	Hor Border (pixels)	
58	00		0	0	Vertical Border (Lines)	
59	1A		26			

5A	Detailed timing/monitor descriptor #3	00	0			ASCII Data Sting Tag
5B		00	0			
5C		00	0			
5D		FE	254			
5E		00	0			D/PN: YJ0MP
5F		59	89		Y	
60		4A	74		J	
61		30	48		0	
62		4D	77		M	
63		50	80		P	
64		80	128		10000000	
65		54	84		T	
66		56	86		V	
67		31	49		1	
68		30	48		0	
69		38	56		8	
6A		46	70		F	
6B		4D	77		M	

EDID:A00

BOE PN

PRODUCT GROUP

REV

ISSUE DATE



TLCM PRODUCT

P5

2016.04.19

SPEC. NUMBER

SPEC. TITLE

PAGE

TV108FHM-AD0-1B10 Preliminary Product Specification

37 OF 37

6C	Detailed timing/monitor descriptor #4	00	0			Product Name Tag (ASCII)
6D		00	0			
6E		00	0			
6F		00	0			
70		00	0			
71		02	2		00000010	8-bit Color Depth & no FRC
72		41	65		01000001	WLED & singal light bar & one light bar
73		21	33		00010001	Frame rate 40Hz~65Hz
74		28	40		00101000	Not use PWM
75		00	0		00000000	Front Surface:Anti-Glare& RGB v-stripe
76		00	0		00000000	Without DBC
77		00	0		00000000	No Motion Blur & no Active Gamma
78		00	0		00000000	No Wireless Enhancement & no In-Cell Scanner
79		0A	10		00001010	2 Lane edp1.3
7A		01	1		00000001	Built-In Self Test
7B		0A	10			
7C	20	32				
7D	20	32				
7E	Extension flag	00	0			
7F	Checksum	74	116	116	-	